

Union Special®

INDUSTRIAL SEWING EQUIPMENT

ILLUSTRATED PARTS LIST

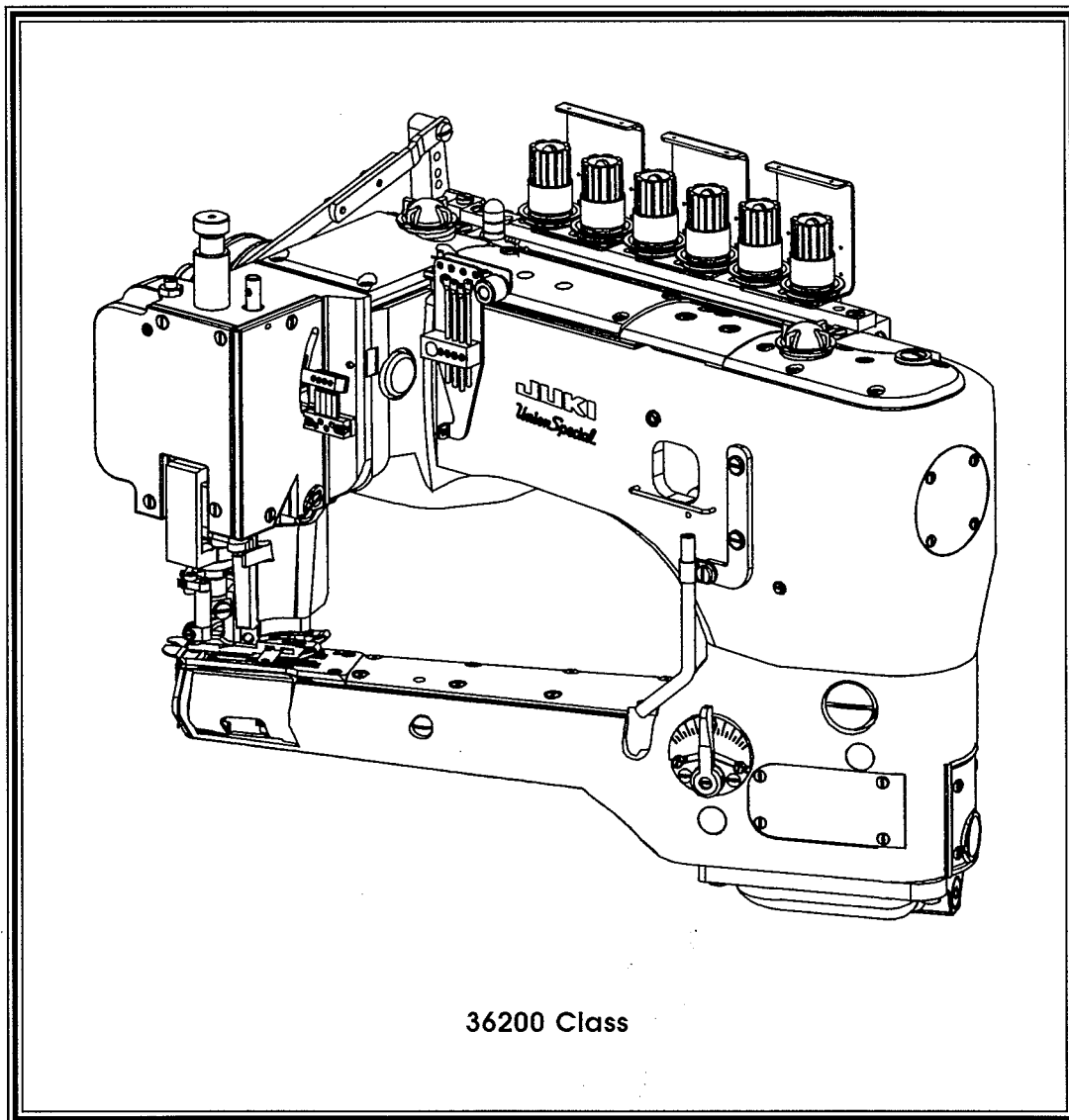

36200 Class

MANUAL NO. PRT9201

STYLES

36200 AK
36200 PA
36200 PH
36200 PJ
36200 PM
36200 PX

36200 TA
36200 TH
36200 TJ
36200 TM
36200 TX

Manual No. PT9201 Illustrated Parts List for 36200 Series Machines

Third Edition Copyright 1994

By

Union Special Corporation Rights Reserved In All Countries

Printed in U.S.A. August 1994

PREFACE

This parts manual has been prepared to assist you in locating individual parts or assemblies on 36200 Series machines. It can be used in conjunction with Union Special Adjusting Manual IN9202.

It is the desire of Union Special that each machine run at its optimum performance. Parts listed in this manual are designed specifically for your machine and are manufactured with utmost precision to assure long lasting service.

This manual has been comprised on the basis of available information. Changes in design and/or improvements may incorporate a slight modification of configuration in illustrations or part numbers.

On the following pages are illustrations and terminology used in describing the parts used on 36200 Series machines.

SAFETY RULES



General Operating Directions

The sewing machines described in this instruction manual are prohibited from being put into service until it has been ascertained that the sewing units, in which these sewing machines will be built-in have conformed with the EC Council Directives (89/392/EEC, Annex II B).

1. Before putting the machines described in this manual into service, carefully read the instructions. The starting of each machine is only permitted after taking notice of the instructions and by qualified operators.

IMPORTANT! Before putting the machine into service, also read the safety rules and instruction from the motor supplier.

2. Observe the national safety rules valid for your country.
3. Each machine is only allowed to be used as foreseen. The foreseen use of the particular machine is described in paragraph "STYLES OF MACHINES" of this instruction manual. Another use, going beyond the description, is not as foreseen.
4. All safety devices must be in position when the machine is ready for work or in operation. Operation of the machine without the appertaining safety devices is prohibited.
5. The following safety devices are components of the sewing machines: Sewing guard, needle lever eyelet guard, needle bar guard, needle break protection shield and handwheel-belt guard.
6. When gauge parts are exchanged (i.e. needle, presser foot, needle plate, feed dog and bobbin), during threading, when the operator leaves the workplace, during service work, the machine must be isolated form the mains by switching off the main switch or disconnecting the main plug. On mechanically operated clutch motors without a start inhibitor it is necessary to wait until the motor has stopped.

7. Wear safety glasses.
8. In case of machine conversions and changes all valid safety rules must be considered. Conversions and changes are made at your own risk.
9. Commissioning of the sewing head is prohibited until such time as the entire sewing unit is found to comply with EC regulations.
10. The warning hints in the instructions are marked with one of these two symbols:



Items require special attention



Danger of injury to operative or service staff

Be sure to observe and adhere to these indications and to the generally applicable regulations.

Special Operating Directions

11. For the following the machine has to be disconnected from the power supply by turning off the main switch or by pulling out the main plug:
 - 11.1 For threading needle(s), looper, spreader etc.
 - 11.2 For replacing sewing tools such as needle, presser foot, throat plate, looper, spreader, feed dog, needle guard, folder, fabric guide etc.
 - 11.3 When leaving the workplace and when the workplace is unattended.
 - 11.4 For maintenance work.
 - 11.5 When using clutch motors without actuation lock, wait until the motor is stopped totally.

General Maintenance Directions

12. Maintenance, repair and conversion work (see item 8) must be done only by trained technicians or special skilled personnel under consideration of the instructions.
13. Any work on the electrical equipment must be done by an electrician or under direction and supervision of special skilled personnel.

Special Maintenance Directions

14. Work on parts and equipment under electrical tension is not permitted.
15. Before doing maintenance and repair work on the pneumatic equipment, the machine has to be disconnected from the compressed air supply. In case of existing residual air pressure after disconnecting from compressed air supply (i.e. pneumatic equipment with air tank), the pressure has to be removed by bleeding.

Exceptions are only allowed for adjusting work and function checks done by special skilled personnel.

Standards

17. The sewing machines described in this manual are built according to the following standards:
 - EN292-2 Safety of machinery-basic concepts, general principles for design.
 - IEC204-3-1/EN60204-3-1 Electrical equipment of industrial machines. Part 3: Particular requirements for sewing machines, units and systems.

CONTENTS

• IDENTIFICATION OF MACHINES	5
• CLASS DESCRIPTION	5
• STYLE OF MACHINES	5
• ILLUSTRATIONS	5
• ILLUSTRATIONS (CONT.)	6
• IDENTIFYING PARTS	6
• NEEDLES	6
• TERMS	6
EXPLODED VIEWS	
• OIL SIGHT GAUGES, TOP COVERS & MISCELLANEOUS TAKEUP & EYELET PARTS	9
• MAIN FRAME, BUSHINGS & MISCELLANEOUS EYELET & COVER PARTS	11
• MAIN SHAFT & MISCELLANEOUS OILING	13
• CRANKSHAFT & NEEDLE LEVER PARTS	15
• FOOT LIFTER & TENSION PARTS	17
• DETACHABLE HEAD, HEAD COVERS, NEEDLE BAR & NEEDLE BAR HEAD	19
• DIFFERENTIAL & MAIN FEED BARS, FEED DOGS & FEED LIFT ECCENTRIC ASSEMBLY	21
• FEED DRIVE ASSEMBLY, FEED ROCKER & LOOPER AVOID PARTS	23
• KNIFE DRIVING PARTS	25
• LOOPER ROCKER SHAFT & LOOPER ROCKER DRIVE PARTS	27
• LAP FORMER, MISCELLANEOUS CYLINDER COVERS, THROAT PLATE, & CHAIN CUTTING KNIFE	29
• CYLINDER BUSHINGS, DIFFERENTIAL FEED CONTROL ASSEMBLY & MISCELLANEOUS CYLINDER COVERS	31
• PRESSER FEET	33
• PRESSER FEET	35
• PRESSER FOOT SHOES	37
• THREAD STAND	39
• MISCELLANEOUS GAUGES & TAPE REEL PARTS	41
• DRIVE UNIT, BELT GUARD & TABLE MOUNTING PARTS	43
• NUMERICAL INDEX OF PARTS	44
• NUMERICAL INDEX OF PARTS	45

IDENTIFICATION OF MACHINES

Each UNION SPECIAL machine is identified by a style number, which is stamped into the style plate affixed to the middle of the machine under the tension assembly.

The serial number is stamped in the casting at the right rear base of the machine.

DESCRIPTION OF MACHINES

Feed-off-the-arm, high speed, medium throw, five or six thread machine. There are four needles and one retainer abreast, one looper and a manually adjusted differential feed control. There is an enclosed automatic lubricating system, filter type oil return pump, visual sight oil action and supply gauges. The maximum work space in front of the needles is 8 inches (203.2mm). Recommended speed - 4200 R.P.M. for all Styles. Styles starting with a 'T' are prepared for table installation and styles starting with a 'P' are prepared for pedestal installation.

STYLE OF MACHINES

- 36200AK** **FLATSEAMER:** Six thread dial adjusted differential feed. For simultaneously trimming and flatseaming knit undergarments, infants clothing and similar light to medium weight materials where closing elastic is required. Seam specifications 607-FSa-1. Components produce a .205" (5.2mm) wide seam.
- 36200TA** **FLATSEAMER:** Six thread dial adjusted differential feed. For simultaneously trimming and flatseaming knit undergarments, infants clothing and similar light to medium weight materials where closing elastic is required. Seam specifications 607-FSa-1. Components produce a .205" (5.2mm) wide seam. Recommended needle 118 GKS, size 075/029, needle 36211, size 070/027. Maximum recommended speed 4200 RPM
- 36200TH** **LAP-FLATSEAMER:** Six thread dial adjusted differential feed. For simultaneously trimming and closing the crotch seam on men's knit briefs when the added strength of a reinforced seam is required. Also used where crossing elastic and heavy seams, such as leg bindings is necessary. The right section of the sewing parts are raised .050" (1.27mm) to assure a better lap seam. Seam specifications 607-LSa-1. Components produce a .205" (5.2mm) wide seam.
- 36200TJ** **FLATSEAMER:** *Same as 36200TA except fitted with components that produce a .236" (6mm) wide seam.* Six thread dial adjusted differential feed. For simultaneously trimming and flatseaming knit undergarments, infants clothing and similar light to medium weight materials where closing elastic is required. Seam specifications 607-FSa-1. Components produce a .205" (5.2mm) wide seam.
- 36200TM** **FLATSEAMER:** *Same as 36200TH except fitted with components that produce a .236" (6mm) wide seam.* Six thread dial adjusted differential feed. For simultaneously trimming and closing the crotch seam on men's knit briefs when the added strength of a reinforced seam is required. Also used where crossing elastic and heavy seams, such as leg bindings is necessary. The right section of the sewing parts are raised .050" (1.27mm) to assure a better lap seam. Seam specifications 607-LSa-1. Components produce a .205" (5.2mm) wide seam.
- 36200TX** **TAPE-SEAMER:** Five thread dial adjusted differential feed. Simultaneously trims, joins and tapes the front of knit briefs in one operation. Fitted with a taping foot that has the tape slot in front of the needle hole and folder that takes a 3/4" (19.0mm) knitted strip, cut with the wale, to produce a 7/16" (11.1mm) wide finished tape. Seam specifications 607-FSp-4 modified. Seam width is .205" (5.2mm).
- 36200PA** **FLATSEAMER:** *Same as 36200TA except prepared for pedestal installation.* Six thread dial adjusted differential feed. For simultaneously trimming and flatseaming knit undergarments, infants clothing and similar light to medium weight materials where closing elastic is required. Seam specifications 607-FSa-1. Components produce a .205" (5.2mm) wide seam.

- 36200PH** **LAP-FLATSEAMER :** *Same as 36200TH except prepared for pedestal installation. Six thread dial adjusted differential feed. For simultaneously trimming and closing the crotch seam on men's knit briefs when the added strength of a reinforced seam is required. Also used where crossing elastic and heavy seams, such as leg bindings is necessary. The right section of the sewing parts are raised .050" (1.27mm) to assure a better lap seam. Seam specifications 607-LSa-1. Components produce a .205" (5.2mm) wide seam.*
- 36200PJ** **FLATSEAMER:** *Same as 36200TJ except prepared for pedestal installation. Same as 36200TA except fitted with components that produce a .236" (6mm) wide seam. Six thread dial adjusted differential feed. For simultaneously trimming and flatseaming knit undergarments, infants clothing and similar light to medium weight materials where closing elastic is required. Seam specifications 607-FSa-1. Components produce a .205" (5.2mm) wide seam.*
- 36200PM** **FLATSEAMER:** *Same as 36200TM except prepared for pedestal installation. Same as 36200TH except fitted with components that produce a .236" (6mm) wide seam. Six thread dial adjusted differential feed. For simultaneously trimming and closing the crotch seam on men's knit briefs when the added strength of a reinforced seam is required. Also used where crossing elastic and heavy seams, such as leg bindings is necessary. The right section of the sewing parts are raised .050" (1.27mm) to assure a better lap seam. Seam specifications 607-LSa-1. Components produce a .205" (5.2mm) wide seam.*
- 36200PX** **TAPE-SEAMER:** *Same as 36200TX except prepared for pedestal installation. Five thread dial adjusted differential feed. Simultaneously trims, joins and tapes the front of knit briefs in one operation. Fitted with a taping foot that has the tape slot in front of the needle hole and folder that takes a 3/4" (19.0mm) knitted strip, cut with the wale, to produce a 7/16" (11.1mm) wide finished tape. Seam specifications 607-FSp-4 modified. Seam width is .205" (5.2mm).*

ILLUSTRATIONS

This manual has been arranged to simplify ordering repair parts. Exploded views of various sections of the mechanism are shown so that the parts may be seen in their actual position in the machine. On the page opposite the illustration will be found a listing of the parts with their part numbers, description and the number of pieces required in the particular view being shown.

Numbers in the first column are reference numbers only, and merely indicate the position of the part in the illustration. The reference number should never be used in ordering parts. Always use the part number listed in the second column.

Component parts of sub-assemblies which can be furnished for repairs are indicated by indenting their descriptions under the description of the main sub-assembly. As an example refer to the following text.

- | | | | |
|-----|----------|---|---|
| 9. | 29126 EC | Upper Looper Drive Shaft Assembly | 1 |
| 10. | 22503 F | Screw | 1 |
| 11. | 39543 E | Cam Follower Locking Clamp | 1 |

It will be noted in the previous example that the cam follower, bushing and cam guide and the upper looper drive shaft are not listed. The reason is that replacement of these parts individually is not recommended, so the complete upper looper drive shaft assembly should be ordered.

When a part is common to all machines covered in this manual, no specific usage will be mentioned in the description. However, when the parts for the various machines are not the same, the specific usage will be mentioned in the description and, if necessary, the difference will be shown in the illustration.

A numerical index of all the parts shown in this manual is located at the back. This will facilitate locating the illustration and description when only a part number is known.

IDENTIFYING PARTS

Where the construction permits, each part is stamped with its part number. On some of the smaller parts and on those where construction does not permit, an identification letter is stamped in to distinguish the part from similar ones.

PLEASE NOTE: Part numbers represent the same part, regardless of which manual they appear. On all orders please include part number, name and style of machine for which the part was ordered.

NEEDLES

Each needle has both a type and size number. The type number denotes the kind of shank, point, length, groove, finish and other details. The size number, stamped on the needle shank, denotes the largest diameter of the blade measured between the shank and the eye. Collectively, the type number and size number represent the complete symbol which is given on the label of all needles packed and sold by Union Special.

TYPE

DESCRIPTION

118GKS 75/029	Round shank, round point, extra short, double groove, struck groove, spotted, chromium plated needle. Sizes available 070/027, 075/029, 080/032.
36211 80/032	Retainer needle, no scarf, chromium plated. Sizes available 065/025, 070/027, 075/029.

When changing the needle, make sure it is fully inserted in the needle driving arm before the nut is tightened.

To have needles promptly and accurately filled, an empty package, a needle sample, or the type and size number should be forwarded. Use the description on the label. A complete order should read as follows: "100 needles, type 130 GS, size 125/049 ".

APPLICATION

118GKS Recommended for Styles 36200AK, PA, PH, PJ, PM, TA, TH, TJ, TM.

118GKS Recommended for Styles 36200PX, TX.

TERMS

Prices are net cash and subject to change without notice. All shipments are forwarded F.O.B. shipping point. A charge is made to cover postage and insurance.

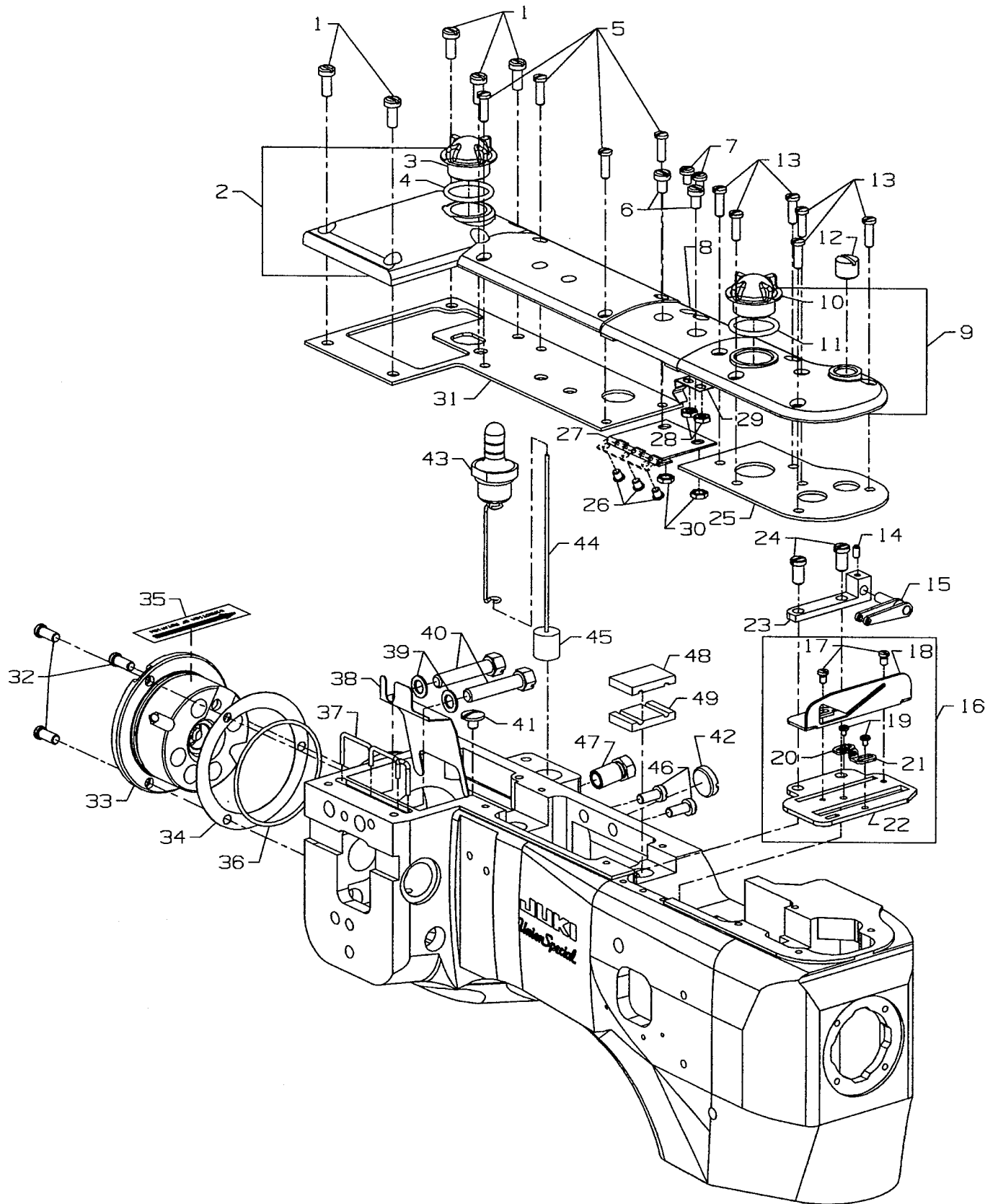

OIL SIGHT GAUGES, TOP COVERS & MISCELLANEOUS TAKEUP & EYELET PARTS

Ref. No.	Part No.	Description	Amt. Req.
1.	93	Screw, for crank chamber cover	5
2.	35888 N	Crank Chamber Cover	1
3.	B3530555000	Oil Sight Gauge	1
4.	660-212	"O"Ring	1
5.	22516 A	Screw	4
6.	93 A	Screw, for middle top cover	2
7.	90	Screw, for spring	2
8.	35887 X	Top Cover, middle	1
9.	35887 AE	Top Cover, front	1
10.	B3530555000	Oil Sight Gauge	1
11.	660-212	"O"Ring	1
12.	22539 M	Plug Screw	1
13.	22516 A	Screw, for front top cover	6
14.	73 C	Screw	1
15.	36256	Cover Thread Take-up Eyelet	1
16.	29476XC	Cast-Off Plate Assembly	1
17.	22 KH	Screw, for cast-off	2
18.	36204	Cast-off	1
19.	73 A	Screw, for cast-off plate eyelets	2
20.	52958 F	Cast-off Plate Eyelet, rear	1
21.	52958 C	Cast-off Plate Eyelet, front	1
22.	36204 A	Cast-off Plate	1
23.	36256 A	Cover Thread Take-up Eyelet Holder	1
24.	22839	Screw	2
25.	35887 AG	Gasket, for front top cover	1
26.	22564 B	Screw, for middle cover hinge	3
27.	35887 R	Middle Cover Hinge	1
28.	41071 G	Nut, for top middle cover spring screw	2
29.	35887 M	Spring, for middle top cover	1
30.	12934 A	Nut, for top middle cover spring screw	2
31.	35888 T	Gasket, for crank chamber	1
32.	22569 B	Screw, for bushing housing	1
33.	36290 D	Bushing Housing, includes bushing	1
34.	56390 E	Gasket, for bushing housing	1
35.	LA528	Directional Label	1
36.	660-935	"O"Ring	1
37.	CL21	Oil Wick	1
38.	35889 H	Oil Shield	1
39.	6042 A	Washer, for screw	2
40.	22759 A	Screw, for connecting head to main frame	2
41.	22711	Screw, for oil wick	1
42.	22539 AA	Plug Screw	1
43.	36293 B	Oil Sight Gauge	1
44.	36293 E	Oil Level Indicator	1
45.	39593 C	Oil Gauge Float	1
46.	93	Screw, for oil pump housing	2
47.	35890 P	Bushing	1
48.	35893 G	Seal, Upper	1
49.	35893 H	Seal, Lower	1

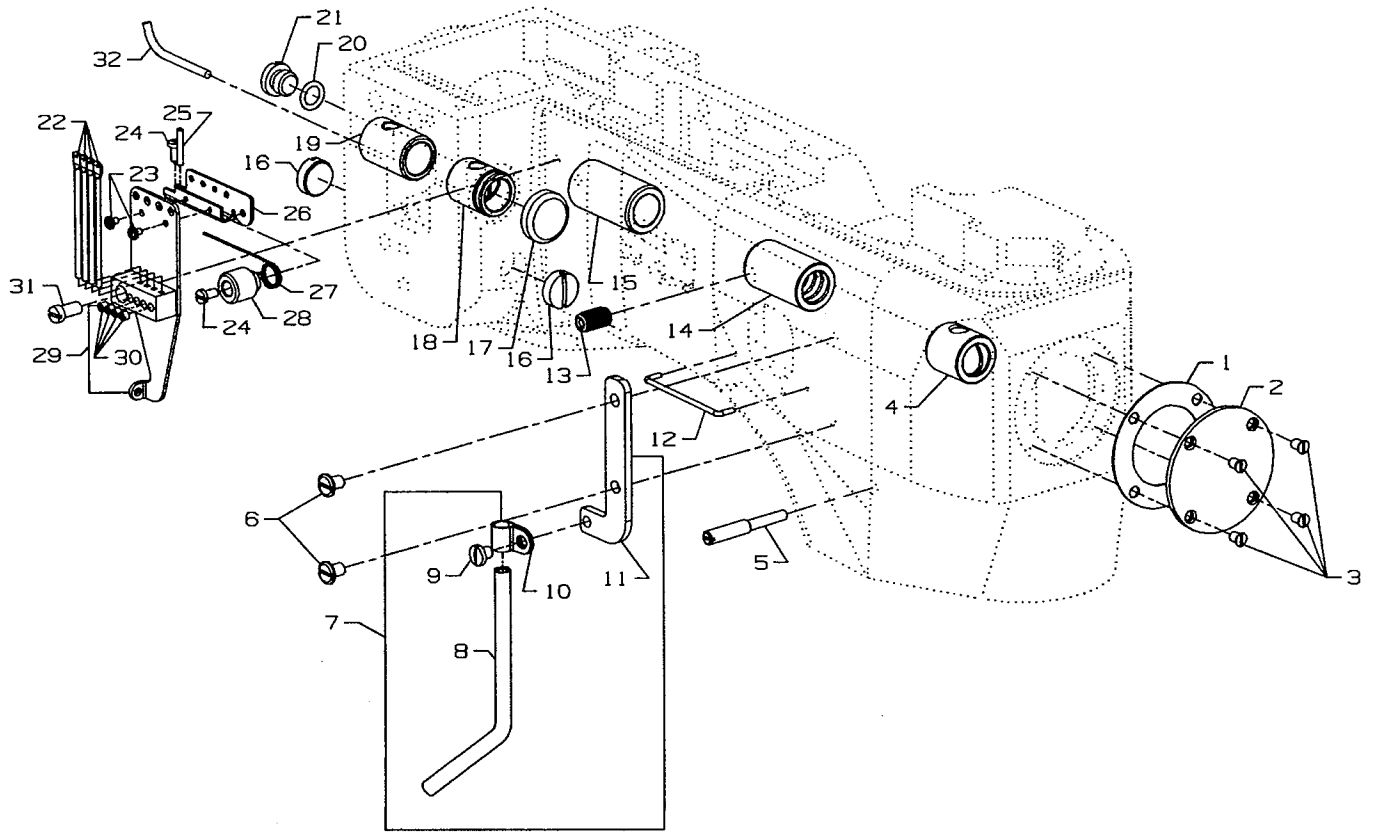

MAIN FRAME, BUSHINGS & MISCELLANEOUS EYELET & COVER PARTS

Ref. No.	Part No.	Description	Amt. Req.
1.	35887 AF	Gasket, end cover	1
2.	35887 Z	End Cover	1
3.	22564 B	Screw, end cover	4
4.	36290 B	Main Shaft Bushing, front	1
5.	22791 D	Screw, for looper drive lever shaft	1
6.	22829	Screw, looper thread shield	2
7.	29105 BH	Looper Thread Shield	1
8.	35866 A	Tube	1
9.	SS7110510SP	Screw	1
10.	35866 B	Tube Clamp	1
11.	35883 AL	Support	1
12.	35781 D	Looper Thread Guide Wire	1
13.	62271 B	Thread Guide	1
14.	36290 A	Main Shaft Bushing, rear	1
15.	35890 E	Crankshaft Bushing, front	1
16.	22539 T	Plug Screw	2
17.	35761 D	Bushing Cap	1
18.	35760 D	Needle Lever Shaft Bushing, front	1
19.	36260	Needle Lever Shaft Bushing, rear	1
20.	660-206	Rubber "O" Ring	1
21.	22733 B	Oil Drain Screw	1
22.	36271 A	Frame Needle Thread Eyelet	4
23.	73 A	Screw, for needle thread eyelet	2
24.	22768 B	Screw, for unlocking spring height adjusting	1
25.	22799 B	Screw	2
26.	36271 G	Stitch Unlocker Mounting Bracket	1
27.	36271 E	Unlocking Spring	1
28.	36271 H	Spring Holder	1
29.	36271	Needle Thread Eyelet	1
30.	28 C	Screw	4
31.	22569 D	Screw, for needle thread eyelet	1
32.	CL21	Oil Wick	1

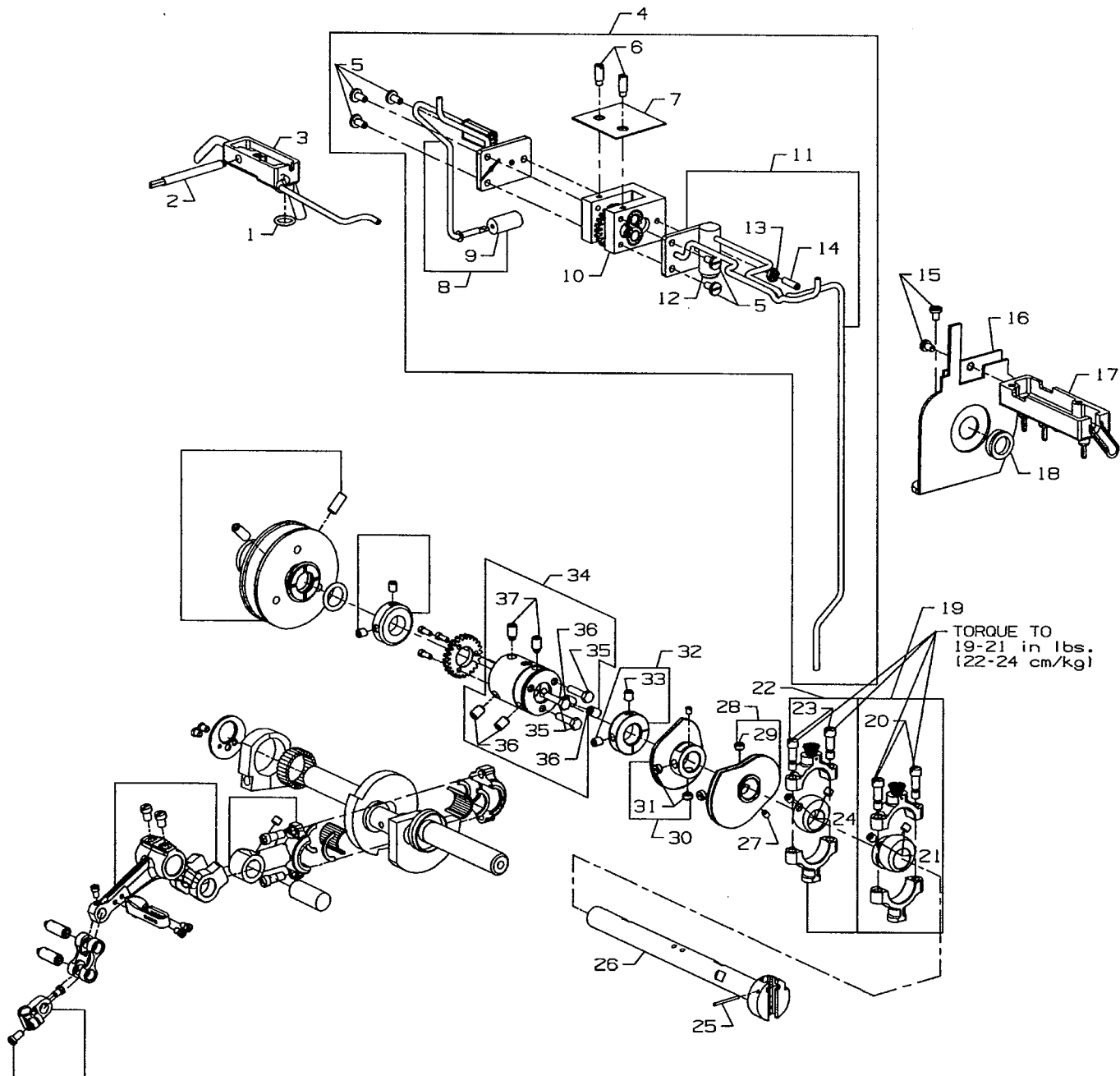

MAIN SHAFT & MISCELLANEOUS OILING

Ref. No.	Part No.	Description	Amt. Req.
1	660-207	Oil Seal Ring	1
2	35897 BU	Reservoir Outlet Tube	1
3	35894 J	Oil Reservoir, back	1
4	29472 Y	Pump Assembly	1
5	22585 A	Screw, for housing cover	5
6	21756 G	Vent Screw	2
7	35897 BW	Gasket	1
8	36297 J	Housing Cover and Oil Tube, rear	1
9	35897 BV	Intake Filter	1
10	29472 AC	Pump Body and Gear Assembly	1
11	36297 M	Housing Cover and Oil Tube, front	1
12	22571 B	Plug Screw	1
13	41071 G	Nut	1
14	22565 A	Screw	1
15	90	Screw, for take-up shield	2
16	36261 A	Take-up Shield Assembly	1
17	35894 L	Oil Reservoir, front	1
18	666-338	Oil Seal Ring	1
19	29101 J	Feed Drive Eccentric Assembly	1
20	22587 E	Screw	2
21	22894 W	Set Screw	2
22	29103 T	Feed Lift Eccentric Assembly	1
23	22587 E	Screw	2
24	22894 W	Set Screw	2
25	660-219 P	Roll Pin	1
26	36222 C	Main Shaft	1
27	22801	Screw	2
28	36223	Double Disc Take-up	1
29	22580	Screw	2
30	36223 A	Cover Thread Take-up	1
31	22580	Screw	2
32	35895 Y	Crankshaft Thrust Collar	1
33	22894 AM	Screw	2
34	35895 X	Main Shaft Coupling	1
35	22519 F	Screw	3
36	22894 J	Set Screw	4
37	22894 K	Spot Screw	2

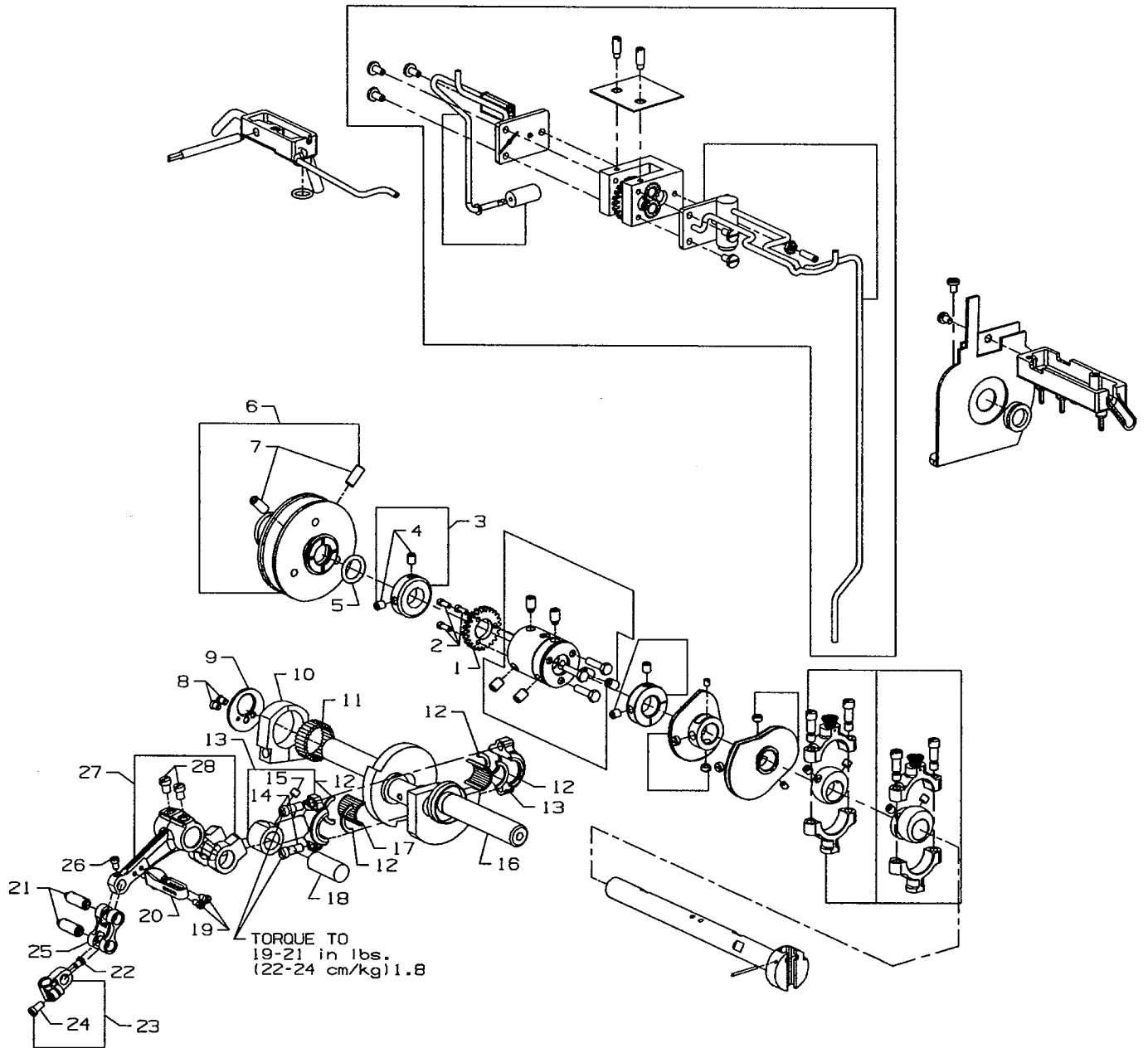

CRANKSHAFT & NEEDLE LEVER PARTS

Ref. No.	Part No.	Description	Amt. Req.
1.	35897 BY	Pump Driving Gear	1
2.	22797	Screw	3
3.	35895 Y	Crankshaft Thrust Collar	1
4.	22894 AM	Screw	2
5.	660-202	Oil Seal Ring	1
6.	36221 D	Pulley, for all Styles	1
7.	22894 E	Screw, for adjustable pulley	2
8.	22766	Screw	2
9.	36251 N	Needle Bearing Retaining Plate	1
10.	36251 M	Eccentric Bearing	1
11.	36263	Needle Bearing Rollers	28
12.	35763 G	Needle Bearing Retaining Ring	4
13.	35862 A	Needle Lever Connecting Rod	1
14.	22587 B	Screw	2
15.	22894 W	Screw	1
16.	36222 A	Crankshaft	1
17.	35763 F	Needle Bearing Rollers	28
18.	35847 X	Needle Lever Connecting Rod Pin	1
19.	77	Screw	2
20.	36264 D	Needle Lever Thread Eyelet	1
21.	51054 A	Link Pin	2
22.	22564	Screw	1
23.	51254 K	Needle Bar Connection	1
24.	22562 A	Screw	1
25.	56354 D	Needle Bar Link	1
26.	77	Screw	1
27.	35815 C	Needle Lever	1
28.	22596 B	Screw	2

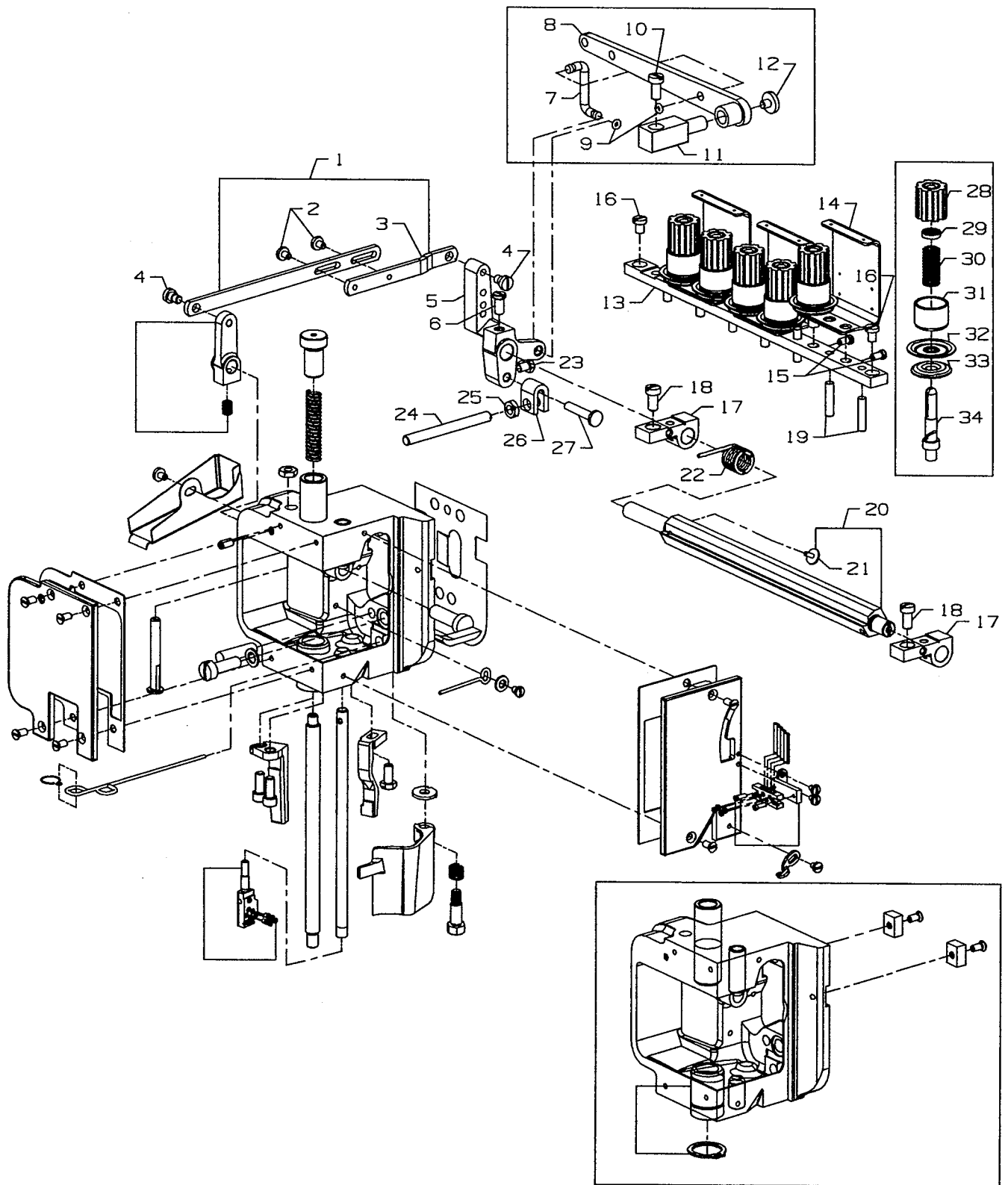

FOOT LIFTER & TENSION PARTS

Ref. No.	Part No.	Description	Amt. Req.
1.	36280 V	Lifter Lever Link Assembly	1
2.	22585 C	Screw	2
3.	36280 U	Lifter Lever Link	1
4.	86	Screw	2
5.	36280 W	Presser Bar Lifter Lever	1
6.	22839 D	Screw	1
*7.	36280 T	Lifter Lever Connecting Link	1
*8.	36280 S	Presser Foot Connection Lifter Lever	1
*9.	660-254 C	Retaining Ring	2
*10.	22517	Screw, for presser foot lifter bearing bracket	1
*11.	36280 N	Presser Foot Lifter Bearing Bracket	1
*12.	255	Screw	1
13.	36298 F	Tension Support	1
14.	36298 G	Tension Thread Eyelet	3
15.	22562 A	Screw, for tension post	6
16.	94	Screw, for tension support	2
17.	36292 M	Tension Plate Bracket	2
18.	22517	Screw, for tension plate bracket	2
19.	35792 T	Tension Disc Release Pin	7
20.	36292 N	Tension Release Shaft	1
21.	22784 F	Screw	1
22.	36292 K	Spring, for tension release shaft	1
23.	22519	Screw, for stop plunger segment pin	1
24.	36280 A	Presser Foot Lifter Stop Plunger	1
25.	258 A	Nut	1
26.	36280 C	Stop Plunger Segment	1
27.	36280 D	Stop Plunger Segment Pin	1
28.	C50092 S	Tension Nut	6
29.	39592 AK	Tension Spring Ferrule	6
30.	51292 F-2	Tension Spring, for cover thread	1
-	51292 F-4	Tension Spring, for looper thread	1
-	51292 F-5	Tension Spring, for needle thread	4
31.	56392 F	Shield, for tension spring	6
32.	35792	Tension Disc, large	6
33.	109	Tension Disc, small	6
34.	36292 P	Tension Post	6

*Available on Styles 36200 TA, TH, TJ, TM, TX

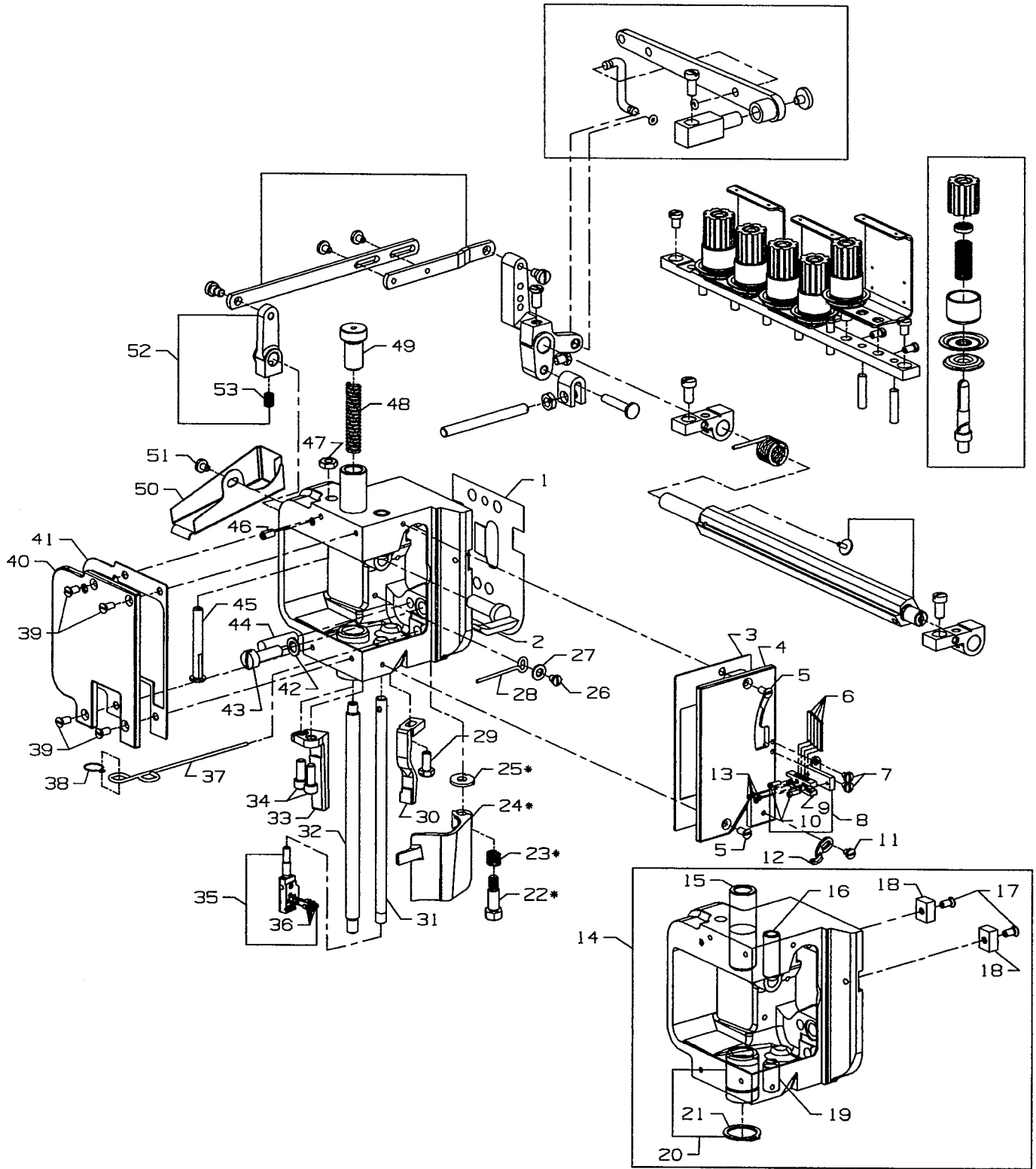

* Items 22, 23, 24, 25, and spanner wrench 21388Y are all part of kit 29480AZJ

DETACHABLE HEAD, HEAD COVERS, NEEDLE BAR & NEEDLE BAR HEAD

Ref. No.	Part No.	Description	Amt. Req.
1.	36289 B	Baffle Plate	1
2.	36280 J	Presser Bar Lifter Lever	1
3.	36289 H	Gasket, for front head cover	1
4.	36289	Head Cover, front	1
5.	22524	Screw, for front head cover	2
6.	36264 B	Needle Thread Strike-off Pin	4
7.	28	Screw, for needle thread take-up	2
8.	36264 E	Needle Thread Take-up, complete	1
9.	36264 F	Strike-off Pin Holder	1
10.	22738 C	Screw, for needle thread take-up	2
11.	28	Screw, for cover thread eyelet	1
12.	51259	Cover Thread Eyelet, for all Styles except 36200 PX, TX	1
13.	28 A	Screw, for needle thread take-up	4
14.	36229 B	Detachable Sewing Head	1
15.	36278 A	Presser Bar Bushing	1
16.	35859 D	Needle Bar Bushing, upper	1
17.	22524	Screw	2
18.	35767	Sewing Head Key	2
19.	35859 J	Needle Bar Bushing, lower	1
20.	36251 D	Cover Thread Carrier and Hook Driving Sleeve Bushing	1
21.	660-261	Retaining Ring	1
22.	22777 B	Screw, for frame chip guard	1
23.	36279 L	Spring, for frame chip guard	1
24.	36279 N	Frame Chip Guard, for Styles 36200 AK, PA, PH, PJ, PM, TA, TH, TJ, TM	1
25.	36279 M	Washer, for frame chip guard	1
26.	22513	Screw, for oil deflector	1
27.	8372 A	Washer	1
28.	36294 C	Oil Deflector	1
29.	22881 A	Screw, for right presser foot guide	1
30.	36278 K	Presser Foot Guide, right	1
31.	35817 E	Needle Bar	1
32.	36278	Presser Bar	1
33.	36278 L	Presser Foot Guide, left	1
34.	22653 B-8	Screw, for left presser foot guide	2
35.	36218	Needle Head, for all Styles except 36200 PJ, PM, TJ, TM	1
-	36218 J	Needle Head, for Styles 36200 PJ, PM, TJ, TM	1
36.	22738 H	Screw, for needles and retainer	5
37.	WO3	Yarn, Oil Wick	1
38.	35897 CK	Oil Wick Hook	1
39.	22524	Screw, for left head cover	4
40.	36289 A	Head Cover, left	1
41.	36289 J	Gasket, for left head cover	1
42.	6042 A	Washer	1
43.	318	Screw, for connecting head to main frame	1
44.	664 F-16	Taper Pin	1
45.	36278 H	Presser Bar Guide Stud	1
46.	22560 A	Screw, for presser bar guide stud	1
47.	12538	Nut, for presser bar guide stud	1
48.	36278 F	Spring, for presser bar	1
49.	36278 M	Presser Bar Regulating Screw	1
50.	36294 B	Oil Guard	1
51.	22585 C	Screw, for oil guard	1
52.	35880 M	Lifter Lever Link Connection	1
53.	22894 J	Screw	1

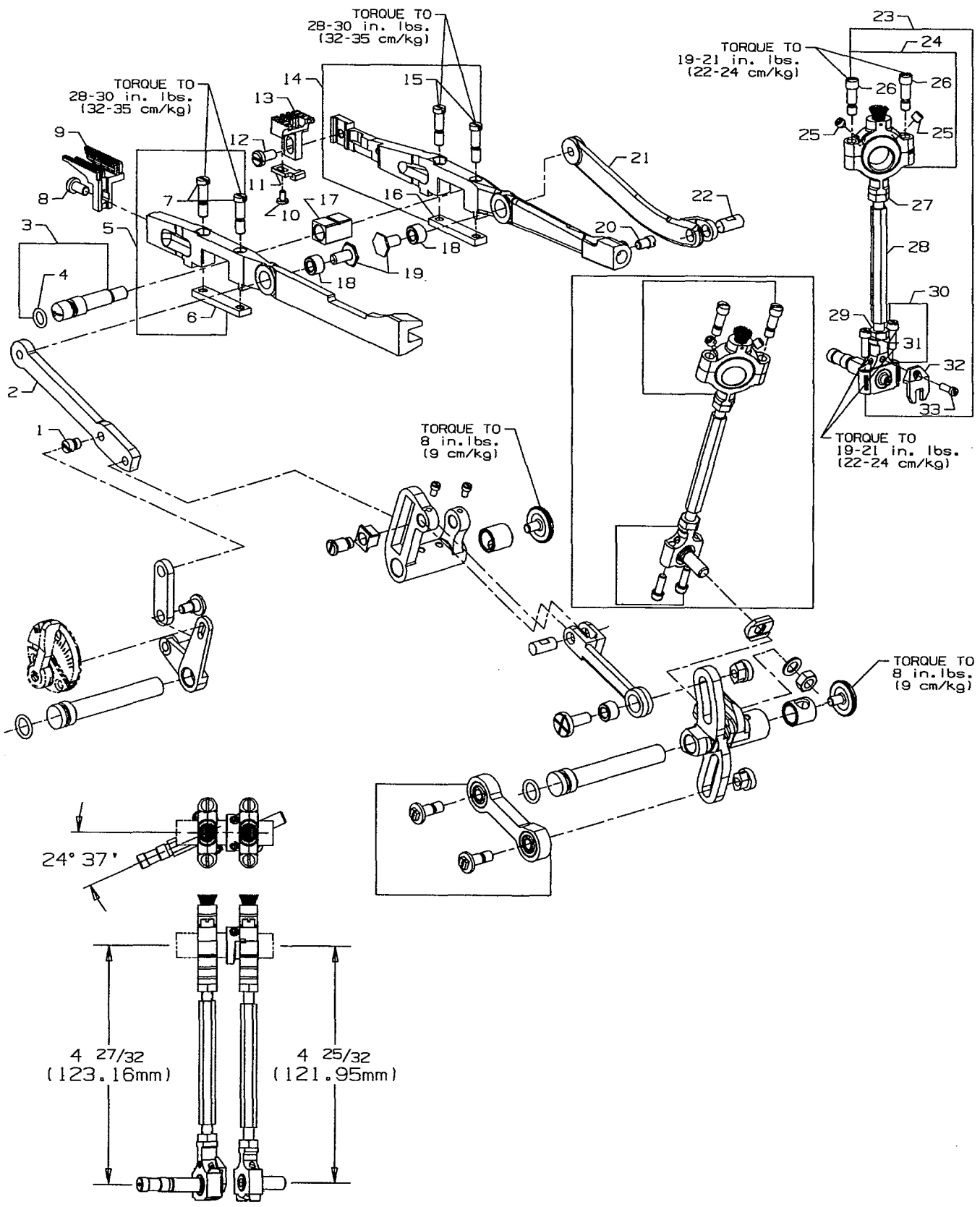

DIFFERENTIAL & MAIN FEED BARS, FEED DOGS & FEED LIFT ECCENTRIC ASSEMBLY

Ref. No.	Part No.	Description	Amt. Req.
1.	22845 M	Screw, for differential feed bar driving link	1
2.	36236 F	Differential Feed Bar Driving Link	1
3.	36234 M	Feed Bar Eccentric Stud	1
4.	660-220	"O"Ring	1
5.	36234 F	Differential Feed Bar	1
6.	36234 G	Feed Bar Plate	1
7.	22587 H	Screw	2
8.	22528	Screw, for differential feed dog	1
9.	36226 A	Differential Feed Dog, marked "FV", 14 teeth per inch, for Styles 36200 AK, PA, PJ, PX, TA, TJ, TX	1
-	36226 B	Differential Feed Dog, marked "PB", 16 teeth per inch	1
-	36226 H	Differential Feed Dog, marked "PQ", 14 teeth per inch, .050" (1.27mm) step on right side, for Styles 36200 PH, TH	1
-	36226 J	Differential Feed Dog, marked "VU", 16 teeth per inch, .050" (1.27mm) step on right side, for Styles 36200 PM, TM	1
10.	87 U	Screw, for needle guard	1
11.	36225	Needle Guard	1
12.	22528	Screw, for main feed dog	1
13.	36205 A	Main Feed Dog, marked "PK", 14 teeth per inch, for Styles 36200 AK, PA, PJ, PX, TA, TJ, TX	1
-	36205 B	Main Feed Dog, marked "PL", 16 teeth per inch	1
-	36205 H	Main Feed Dog, marked "PR", 14 teeth per inch, .050" (1.27mm) step on right side, for Styles 36200 PH, TH	1
-	36205 J	Main Feed Dog, marked "VV", 16 teeth per inch, .050" (1.27mm) step on right side, for Styles 36200 PM, TM	1
14.	36234 E	Main Feed Bar	1
15.	22578 H	Screw	2
16.	36234 G	Feed Bar Plate	1
17.	36234 C	Feed Bar Slide Block	1
18.	36236 H	Bushing	2
19.	36236 G	Driving Link Stud	2
20.	33174 B	Screw	1
21.	36236 E	Main Feed Bar Drive Link	1
22.	62238 A	Link Pin	1
23.	29478 CS	Feed Lift Eccentric Assembly	1
24.	29103 T	Feed Lift Eccentric Assembly Ball Joint	1
25.	22894 W	Set Screw	2
26.	22587 E	Screw	2
27.	269	Nut, left thread	1
28.	36244	Connecting Rod	1
29.	18	Nut, right thread	1
30.	36244 A	Ball Joint, complete	1
31.	22729 C	Screw	2
32.	41255 B	Ball Fork	1
33.	22747	Screw, for ball fork	1

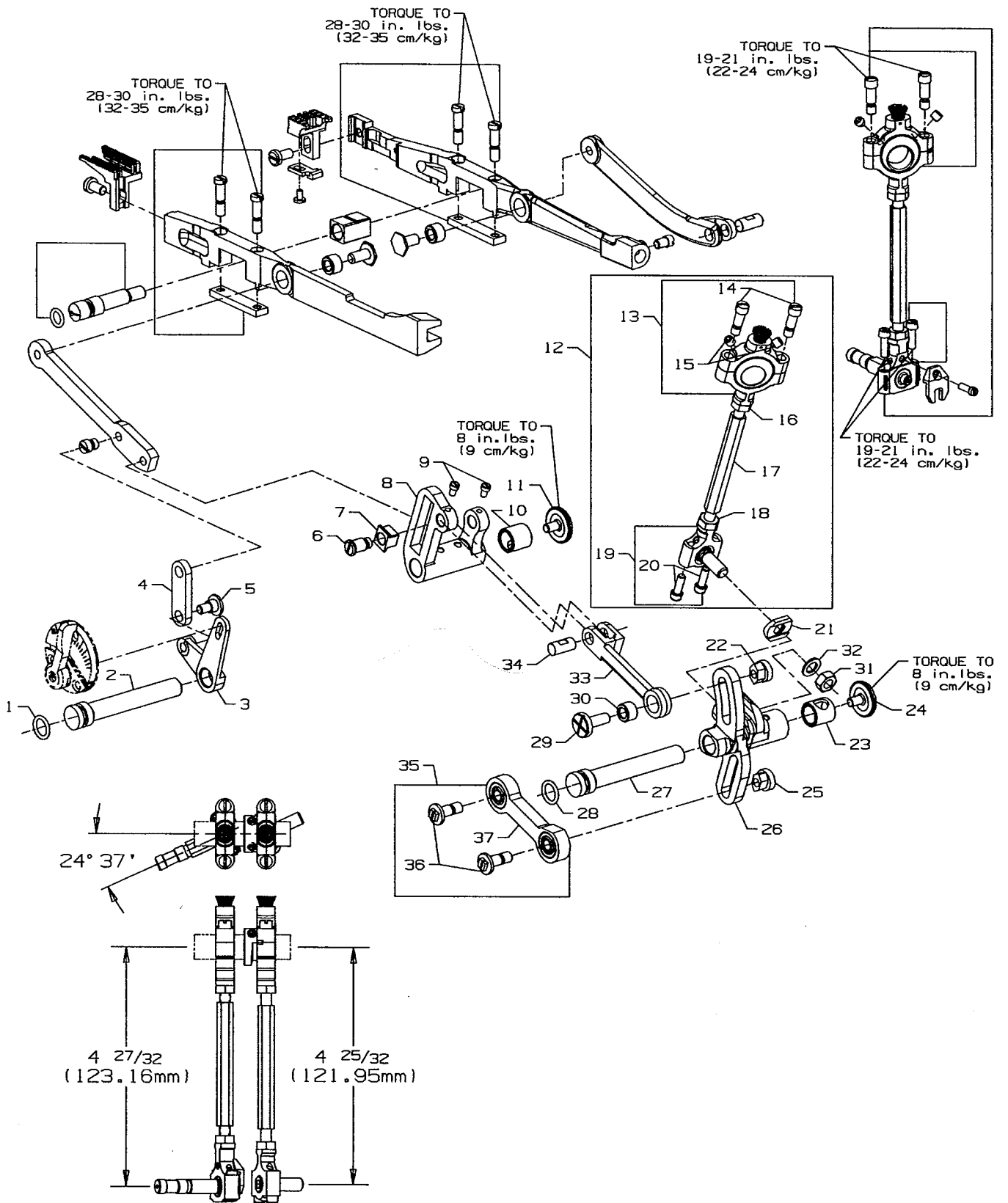

FEED DRIVE ASSEMBLY, FEED ROCKER & LOOPER AVOID PARTS

Ref. No.	Part No.	Description	Amt. Req.
1.	660-207	Oil Seal Ring	1
2.	36236 A	Feed Rocker Shaft	1
3.	36237	Differential Feed Adjusting Lever	1
4.	36237 A	Differential Feed Adjusting Link	1
5.	22504 C	Screw	1
6.	36236 J	Differential Driving Link Stud	1
7.	36236 K	Differential Feed Driving Link Slide Block	1
8.	36236	Feed Rocker	1
9.	77	Screw	2
10.	36236 B	Bushing	1
11.	22733 G	Screw	1
12.	29478 CT	Feed Drive Assembly	1
13.	29101 J	Feed Drive Eccentric Assembly	1
14.	22587 E	Screw	2
15.	22894 W	Set Screw	2
16.	269	Nut, left thread	1
17.	43246	Connecting Rod	1
18.	18	Nut, right thread	1
19.	35846	Ball Joint	1
20.	22729 C	Screw	2
21.	35846 B	Washer	1
22.	35866	Nut	1
23.	36236 B	Bushing	1
24.	22733 G	Screw	1
25.	35766 B	Nut	1
26.	35842 J	Feed Drive and Looper Avoid Drive Lever	1
27.	36236 A	Feed Drive Shaft	1
28.	660-207	Oil Seal Ring	1
29.	35836 C	Screw, for feed rocker driving link	1
30.	36236 H	Bushing	1
31.	258	Nut	1
32.	6042 A	Washer	1
33.	36236 C	Feed Rocker Driving Link	1
34.	62238 A	Link Pin	1
35.	29478 FF	Looper Drive Shaft Cross Head Connecting Rod Assembly	1
36.	35851 N	Screw	2
37.	35851 M	Connecting Rod	1

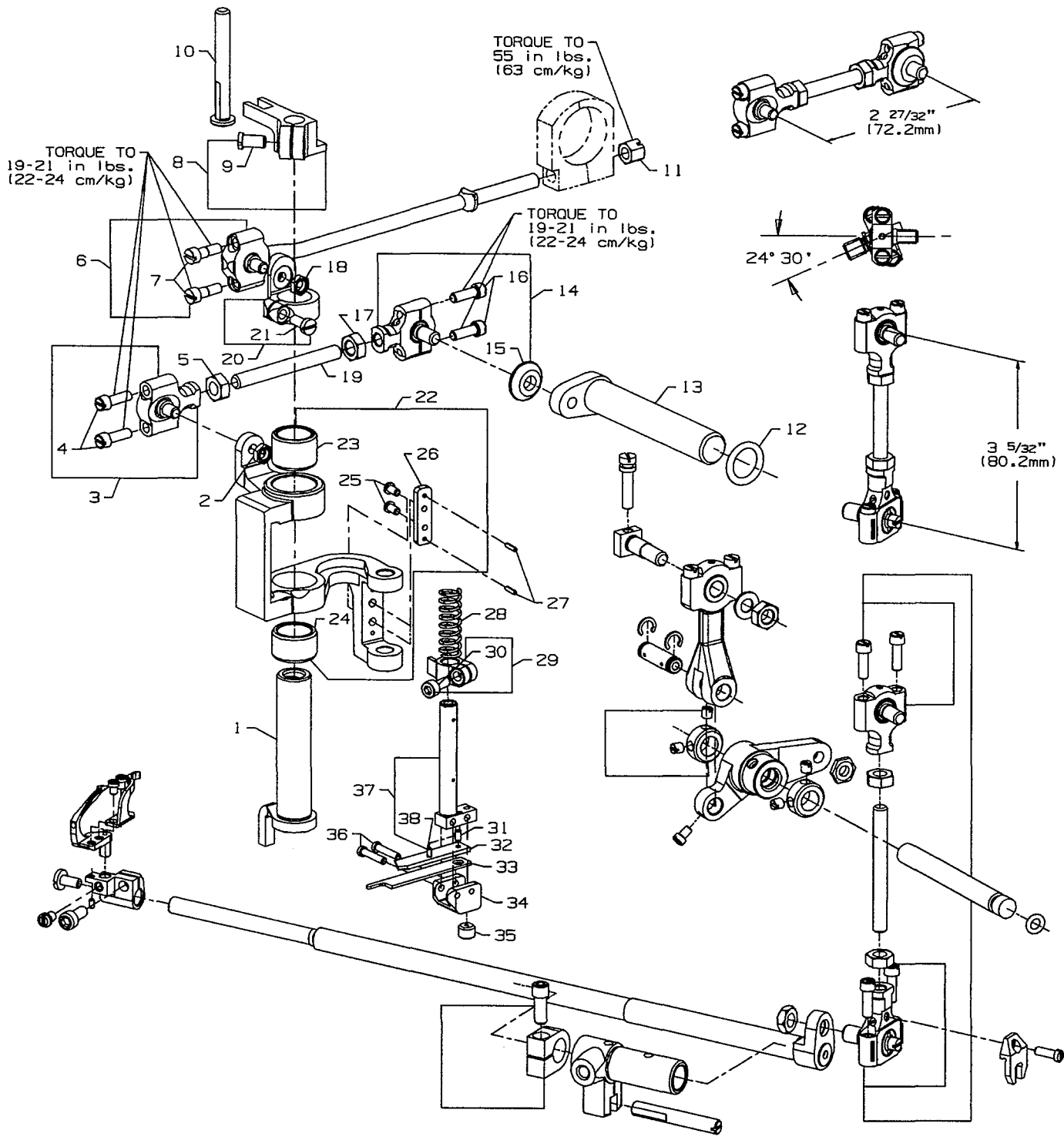

KNIFE DRIVING PARTS

Ref. No.	Part No.	Description	Amt. Req.
1.	36251 B	Cover Thread Carrier and Hook Driving Sleeve	1
2.	12934 A	Nut	1
3.	52848 B	Knife Drive Connection Ball Joint, left	1
4.	22729 C	Screw	2
5.	18	Nut, right thread	1
6.	36251 P	Cover Thread Carrier and Hook Driving Connection Rod Ball Joint	1
7.	97 A	Screw	2
8.	36278 J	Presser Bar Guide	1
9.	22569G	Screw	1
10.	36278 H	Presser Bar Guide Stud	1
11.	52841 H	Nut	1
12.	660-202	Oil Seal Ring	1
13.	36261	Knife Drive Lever	1
14.	52848 C	Knife Drive Connection Ball Joint, right	1
15.	36 G	Washer	1
16.	22729 C	Screw	2
17.	269	Nut, left thread	1
18.	12934 A	Nut	1
19.	4761	Knife Drive Connecting Rod	1
20.	36251 C	Sleeve Driving Lever, for Styles 36200 AK, PA, PH, PX, TA, TH, TX	1
-	36251 V	Sleeve Driving Lever, for Styles 36200 PJ, PM, TJ, TM	1
21.	22585	Screw	1
22.	36273 M	Knife Driving Bracket	1
23.	36273 F	Bushing	1
24.	36273 N	Bushing	1
25.	605 A	Screw	2
26.	36273 J	Knife Holder Guide Plate	1
27.	660-219 D	Roll Pin	2
28.	36273 C	Knife Holder Spring	1
29.	36273 K	Knife Holder Guide Collar	1
30.	22729 M	Screw	1
31.	22799 N	Screw	1
32.	36273 D	Knife Support	1
33.	36270 B	Knife, upper	1
34.	36273 G	Knife Holder	1
35.	22894 X	Screw	1
36.	22767 A	Screw	2
37.	36273 A	Knife Holder Shank	1
38.	1096 B	Screw	1

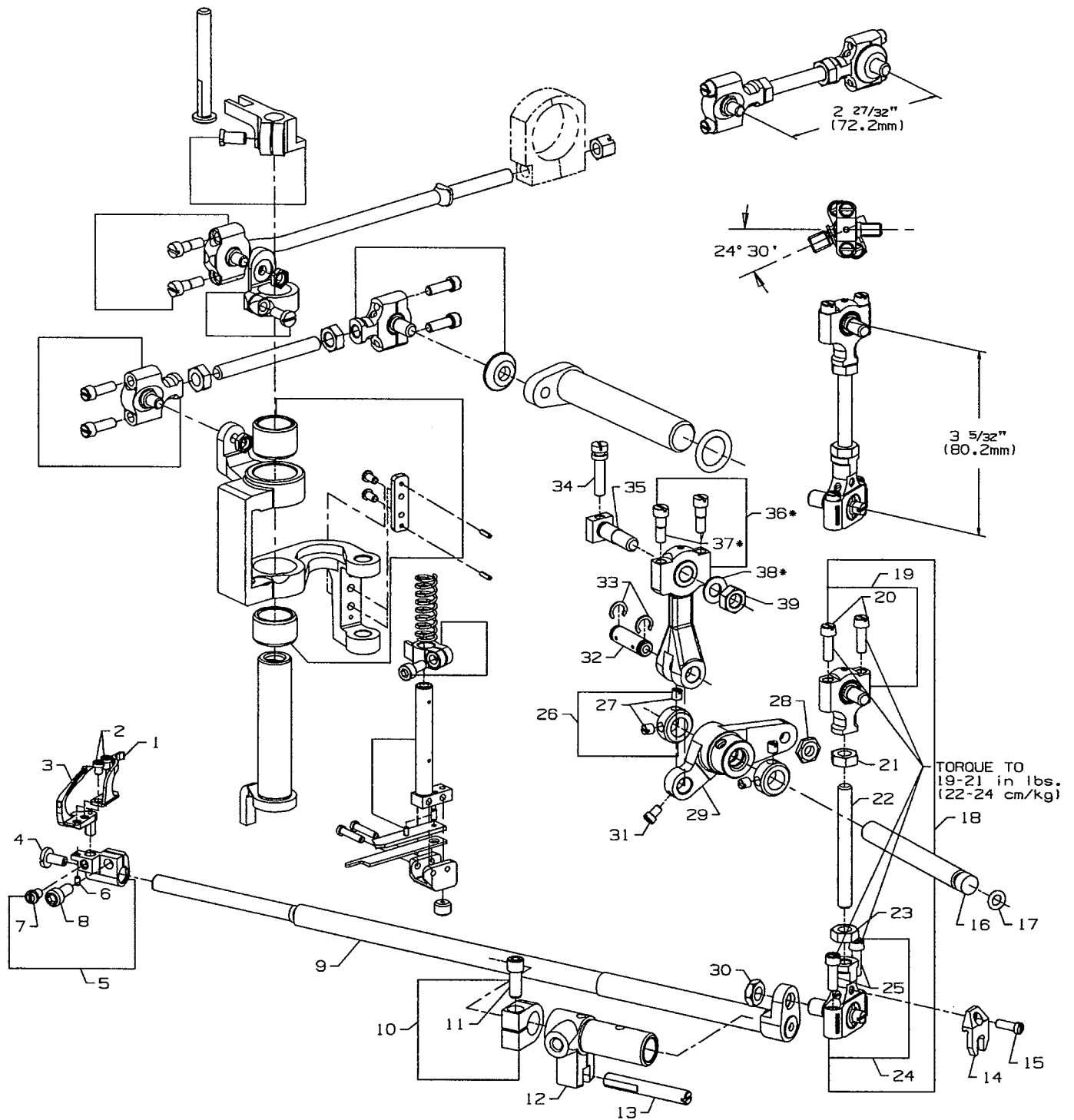

*Items 36, 37, 38, are part of
 Looper Drive connection kit 29478FG

LOOPER ROCKER SHAFT & LOOPER ROCKER DRIVE PARTS

Ref. No.	Part No.	Description	Amt. Req.
1.	36210	Looper Mounted Needle Guard, marked "FZ"	1
2.	604	Screw, for needle guard	2
3.	36208 A	Looper	1
4.	22585 A	Screw	1
5.	36248	Looper Holder	1
6.	1096 B	Looper Adjusting Screw	1
7.	22564 D	Screw	1
8.	22652 A-6	Screw	1
9.	36249	Looper Rocker Shaft	1
10.	35751 G	Looper Shaft Collar	1
11.	22572 B	Screw	1
12.	36249 B	Looper Shaft Sleeve	1
13.	36278 C	Guide Stud	1
14.	41255 B	Ball Fork	1
15.	22747	Screw	1
16.	36253 B	Looper Drive Lever Shaft	1
17.	660-221	Oil Seal Ring	1
18.	29478 CU	Looper Drive Connecting Rod Assembly	1
19.	35851 L	Ball Joint, upper	1
20.	22729 C	Screw	2
21.	269	Nut, left thread	1
22.	4761	Connecting Rod	1
23.	18	Nut, right thread	1
24.	39145 A	Ball Joint, lower	1
25.	22729 C	Screw	2
26.	12865	Collar	2
27.	88	Screw	2
28.	15037 A	Nut	1
29.	36253 A	Looper Drive Lever	1
30.	258 A	Nut	1
31.	77	Screw	1
32.	52336	Link Pin	1
33.	660-215	Retaining Ring	2
34.	22795 B	Screw	1
35.	36253 G	Looper Drive Crank Stud	1
36.	36245 B	Looper Drive Connecting Rod and Ferrule Sub-Assembly	1
37.	97 A	Screw	1
38.	53636 C	Washer	1
39.	269	Nut, left thread	1

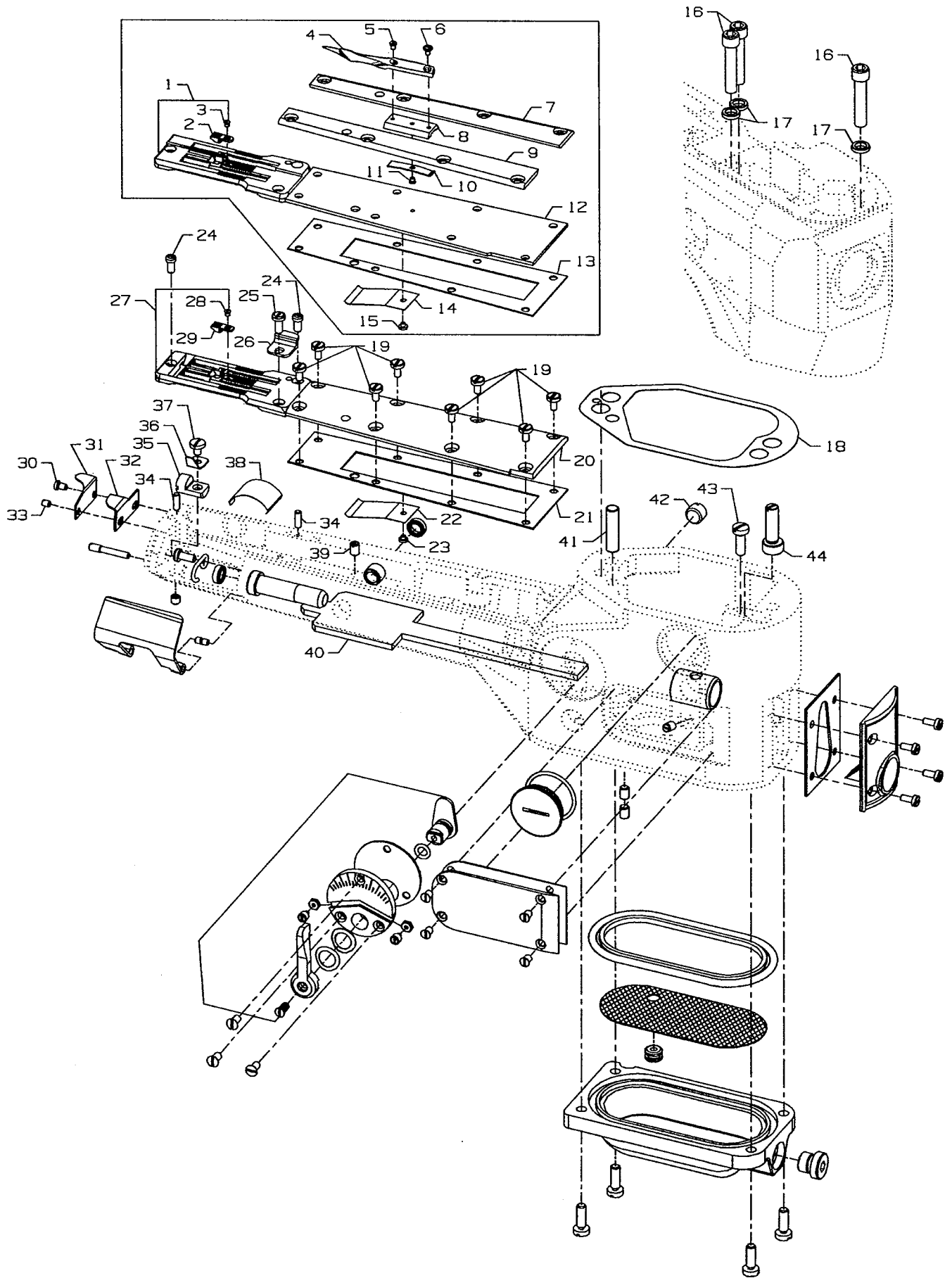

LAP FORMER, MISCELLANEOUS CYLINDER COVERS, THROAT PLATE, & CHAIN CUTTING KNIFE

Ref. No.	Part No.	Description	Amt. Req.
1.	36224 H	Throat Plate, .050" (1.27mm) step on right side, Styles 36200 PH, TH	1
-	36224 K	Throat Plate, .050" (1.27mm) step on right side, Styles 36200 PM, TM	1
2.	36240	Stitch Tongue, marked "D", for Styles 36200 PH, TH	1
-	36240 J	Stitch Tongue, marked "AC", for Styles 36200 PM, TM	1
3.	22716 A	Screw, stitch tongue	1
4.	23420 DB	Lap Former	1
5.	22738 B	Screw, for lap former	1
6.	73 A	Screw, for lap former	1
7.	36283 J	Gib, right	1
8.	23423 X	Lap Former Slide Block	1
9.	36283 H	Gib, left	1
10.	23424 Z	Spring, for lap former slide block	1
11.	22716 A	Screw, for lap former slide block spring	1
12.	36283 G	Cylinder Cover	1
13.	36283 F	Gasket, for cylinder cover	1
14.	36284 E	Upper Lint Shield	1
15.	22798	Screw, upper lint shield	1
16.	22653 E-24	Screw, for joining cylinder to main frame	3
17.	35876 U	Washer	3
18.	36284	Gasket	1
19.	98 A	Screw, for cylinder cover	8
20.	36283 E	Cylinder Cover, for all Styles except 36200 PH, PM, TH, TM	1
21.	36283 F	Gasket, for cylinder cover	1
22.	36284 E	Upper Lint Shield	1
23.	22798	Screw, for upper lint shield	1
24.	22562 A	Screw, for throat plate	3
25.	22849	Screw, for edge guide	1
26.	36203	Edge Guide, for Styles 36200 AK, PA, PJ, TA, TJ	1
27.	C36224 A	Throat Plate, for Styles 36200 AK, PA, PX, TA, TX	1
-	C36224 J	Throat Plate, for Styles 36200 PJ, TJ	1
28.	22716 A	Screw, for stitch tongue	1
29.	36240	Stitch Tongue, marked "D", for Styles 36200 AK, PA, PX, TA, TX	1
-	36240 J	Stitch Tongue, marked "AC", for Styles 36200 PJ, TJ	1
30.	22 KH	Screw, for chain cutting knife	1
31.	36296 B	Guard, for chain cutting knife	1
32.	36296 A	Chain Cutting Knife	1
33.	22801	Screw, for chain cutting knife	1
34.	36251 K	Dowel Pin	2
35.	36283 C	Cylinder Hinged Spring Support Stud	1
36.	36283 B	Spring	1
37.	22585 C	Screw, spring	1
38.	35884 M	Lower Lint Shield	1
39.	531	Screw	1
40.	666-341	Felt	1
41.	22571 A	Plug Screw	1
42.	667 D-16	Dowel Pin	1
43.	22596	Screw, for feed bar eccentric stud	1
44.	36229 A-1	Cylinder Alignment Eccentric Pin	1

*Indicates parts for lap former used on styles 36200 PH, PM, TH, and TM only.

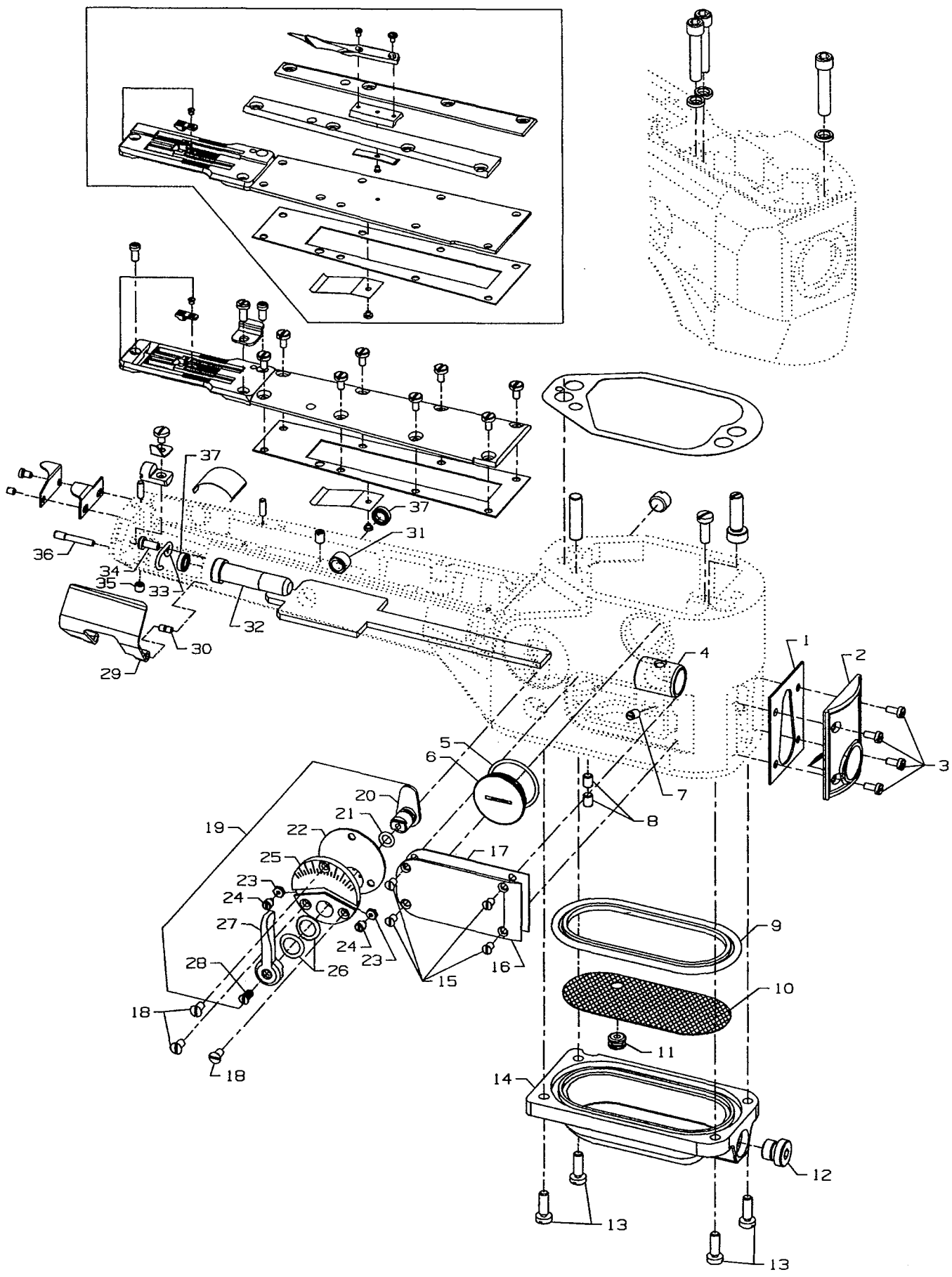

**CYLINDER BUSHINGS, DIFFERENTIAL FEED CONTROL ASSEMBLY &
MISCELLANEOUS CYLINDER COVERS**

Ref. No.	Part No.	Description	Amt. Req.
1.	35884 R	Gasket, for front cylinder cover and oil gauge	1
2.	36284 C	Cylinder Cover and Oil Gauge, front	1
3.	J87 J	Screw, for front cylinder cover and oil gauge	4
4.	36249 A	Bushing, for looper shaft, front	1
5.	660-1115	"O" Ring	1
6.	22539 AL	Plug Screw	1
7.	22560 A	Screw, for guide stud	1
8.	531	Screw	2
9.	36284 F	Gasket, for bottom cover	1
10.	36293 G	Screen, for bottom cover	1
11.	661-150	Rubber "O" Ring, for screen	1
12.	999-196	Magnetic Oil Drain Plug Screw	1
13.	22596	Screw, for bottom cover	4
14.	36282	Bottom Cover	1
15.	22766	Screw, for cylinder side cover	4
16.	36286	Cylinder Side Cover	1
17.	36286 B	Gasket, for cylinder side cover	1
18.	87 A	Screw, for differential feed control assembly	3
19.	29478 CZ	Differential Feed Control Assembly, complete	1
20.	36237 E	Adjusting Lever	1
21.	660-220	Oil Seal Ring	1
22.	36238 F	Gasket	1
23.	60078 Z	Nut	2
24.	36237 H	Stop Screw	2
25.	36238	Adjusting Plate	1
26.	36237 J	Spring Washer	2
27.	36237 K	Operating Lever	1
28.	538	Screw	1
29.	36283 K	Cylinder Hinged Cover	1
30.	35883 G	Pin	1
31.	36237 L	Bushing, for feed bar eccentric stud	1
32.	35850 F	Bushing, for looper shaft, rear	1
33.	36256 B	Looper Thread Guide Wire	1
34.	22849	Screw, for looper thread guide wire	1
35.	22894 W	Screw, for cylinder hinged spring support stud	1
36.	22791 E	Screw Pin	1
37.	660-1117	Oil Seal	2

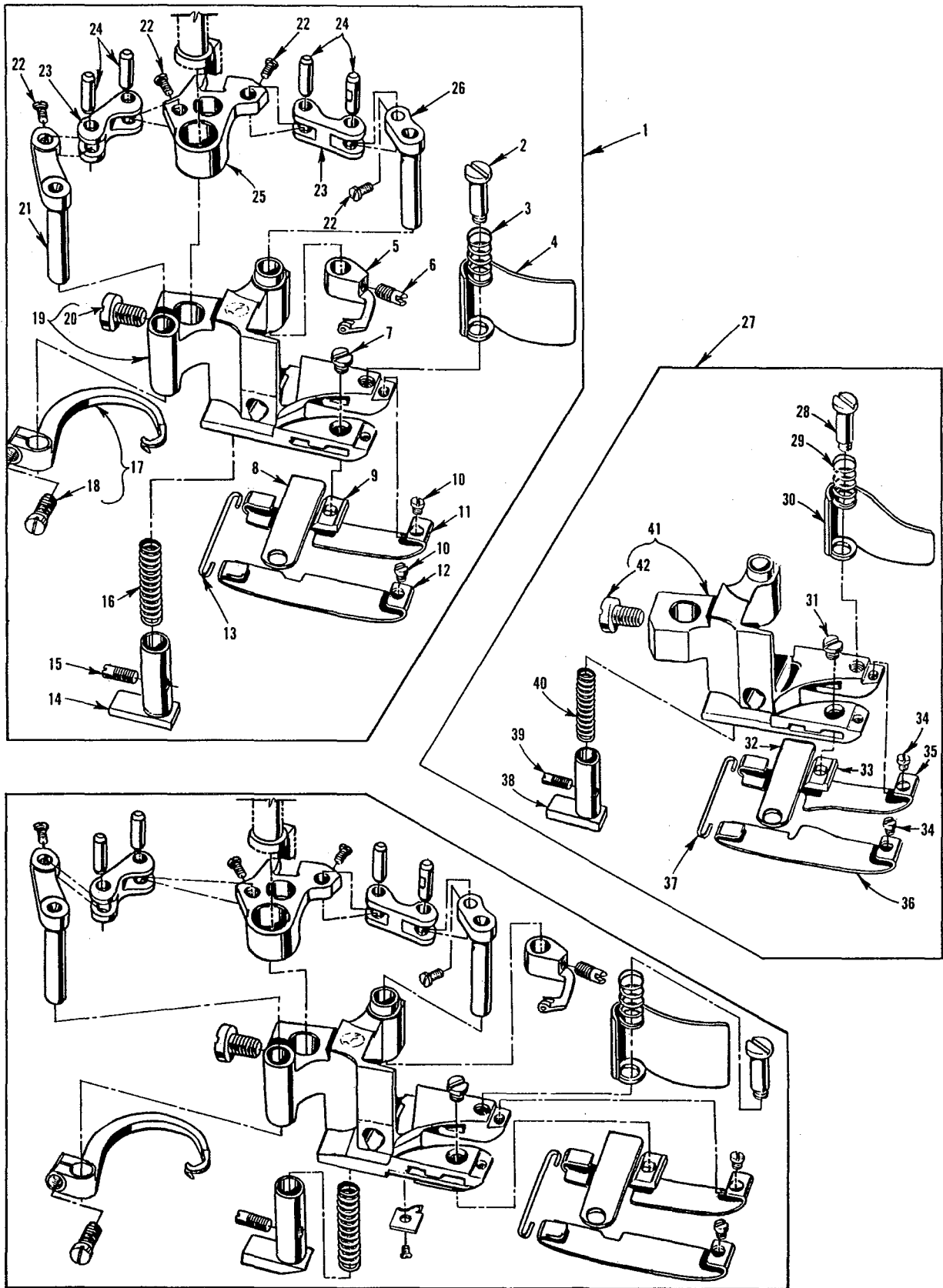

PRESSER FEET

Ref. No.	Part No.	Description	Amt. Req.
1.	36220 A	Presser Foot, complete, for Styles 36200 PA, TA	1
-	36220 K	Presser Foot, complete, for Styles 36200 PJ, TJ	1
-	36220 L	Presser Foot, complete, for Style 36200 AK	1
2.	22731	Screw, for chip guard	1
3.	36279 D	Spring, for chip guard	1
4.	36279 C	Chip Guard	1
5.	36251 E	Cover Thread Carrier, for 36220 A, L presser foot	1
-	36251 W	Cover Thread Carrier, for 36220 K presser foot	1
6.	22565 A	Screw, cover thread carrier	1
7.	150	Screw, for stationary knife clamp	1
8.	36250	Stationary Knife	1
*9.	36250 B	Stationary Knife Clamp, .213" (5.41mm) ID Mark "A"	1
*-	36250 G	Stationary Knife Clamp, .222" (5.64mm) ID Mark "B"	1
*-	36250 J	Stationary Knife Clamp, .226" (5.74mm) ID Mark "J"	1
10.	22738 G	Screw, for presser foot shoe	2
#11.	36232 AH	Presser Foot Shoe, right, for 36220 A, K, L presser foot	1
#12.	36231 AH	Presser Foot Shoe, left, for 36220 A, K, L presser foot	1
13.	36230 D	Shoe Holding Wire	1
14.	36230 J	Yielding Section, for 36220 A, K presser foot	1
-	36230 P	Yielding Section, for 36220 L presser foot	1
15.	22565 A	Screw, for yielding section	1
16.	36230 C	Spring, for yielding section	1
17.	36251 F	Cross Thread Hook, for 36220 A, L presser foot	1
-	36251 FA	Cross Thread Hook, for 36220 K presser foot	1
18.	22562 A	Screw, for cross thread hook	1
19.	36230 U	Presser Foot Base, for 36220 A, K, L presser foot	1
20.	94	Screw, for presser foot base	1
21.	36251 H	Cover Thread Hook Driving Lever and Shaft	1
22.	22738 P	Screw	4
23.	36251 J	Link, for ref. no. 21, 25 and 26	2
24.	36251 K	Link Pin	4
25.	36251 L	Cover Thread Carrier and Hook Driving Segment	1
26.	36251 G	Cover Thread Carrier Driving Lever and Shaft	1
27.	36220 B	Presser Foot, complete, for Styles 36200 PX, TX	1
28.	22731	Screw, for chip guard	1
29.	36279 D	Spring, for chip guard	1
30.	36279 H	Chip Guard	1
31.	150	Screw, for stationary knife clamp	1
32.	36250	Stationary Knife	1
*33.	36250 B	Stationary Knife Clamp, .213" (5.41mm) ID Mark "A"	1
*-	36250 G	Stationary Knife Clamp, .222" (5.64mm) ID Mark "B"	1
*-	36250 J	Stationary Knife Clamp, .226" (5.74mm) ID Mark "J"	1
34.	22738 G	Screw, for presser foot shoe	2
#35.	36232 AL	Presser Foot Shoe, right, for 36220 B presser foot	1
#36.	36231 AL	Presser Foot Shoe, left, for 36220 B presser foot	1
37.	36230 D	Shoe Holding Wire	1
38.	36230 J	Yielding Section	1
39.	22565 A	Screw, for yielding section	1
40.	36230 C	Spring, for yielding section	1
41.	36230 G	Presser Foot Base, for 36220 B presser foot	1
42.	94	Screw, for presser foot base	1

* When replacing the stationary knife clamp, order the clamp that has the same finish as the one being replaced.

#See page 39 for other presser foot shoes available.

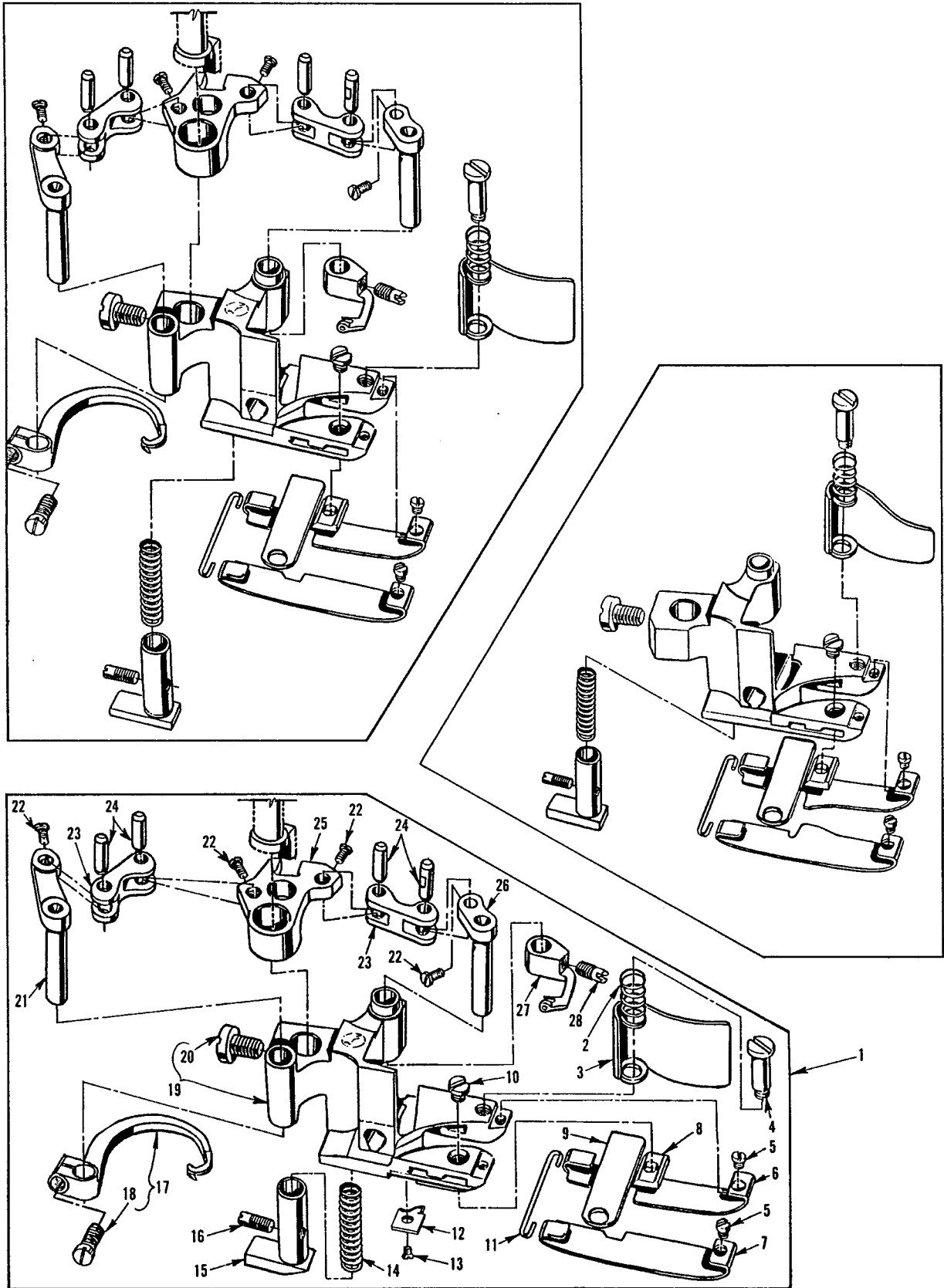

PRESSER FEET

Ref. No.	Part No.	Description	Amt. Req.
1.	36220 H	Presser Foot, complete, for Styles 36200 PH, TH	1
-	36220 M	Presser Foot, complete, for Styles 36200 PM, TM	1
2.	36279 D	Spring, for chip guard	1
3.	36279 C	Chip Guard	1
4.	22731	Screw, for chip guard	1
5.	22738 G	Screw, for presser foot shoe	2
#6.	36232 AM	Presser Foot Shoe, right, for Style 36220 H presser foot	1
#-	36232 AP	Presser Foot Shoe, right, for Style 36220 M presser foot	1
#7.	36231 AM	Presser Foot Shoe, left, for Style 36220 H presser foot	1
#-	36231 AP	Presser Foot Shoe, left, for Style 36220 M presser foot	1
*8.	36250 B	Stationary Knife Clamp, .213" (5.41mm) ID Mark "A"	1
*-	36250 G	Stationary Knife Clamp, .222" (5.64mm) ID Mark "B"	1
*-	36250J	Stationary Knife Clamp, .226" (5.74mm) ID Mark "J"	1
9.	36250	Stationary Knife	1
10.	150	Screw, for stationary knife clamp	1
11.	36230 D	Shoe Holding Wire	1
12.	36230 R	Cloth Guide Plate	1
13.	22716 A	Screw, for cloth guide plate	1
14.	36230 C	Spring, for yielding section	1
15.	36230 P	Yielding Section	1
16.	22565 A	Screw, for yielding section	1
17.	36251 F	Cross Thread Hook, for 36220 H presser foot	1
-	36251 FA	Cross Thread Hook, for 36220 M presser foot	1
18.	22562 A	Screw, for cross thread hook	1
19.	36230 S	Presser Foot Base, for 36220 H presser foot	1
-	36230 V	Presser Foot Base, for 36220 M presser foot	1
20.	94	Screw, for presser foot base	1
21.	63251 H	Cover Thread Hook Driving Lever and Shaft	1
22.	22738 P	Screw	4
23.	36251 J	Link, for ref. no. 21, 25 and 26	2
24.	36251 K	Link Pin	4
25.	36251 L	Cover Thread Carrier and Hook Driving Segment	1
26.	36251 G	Cover Thread Carrier Driving Lever and Shaft	1
27.	36251 E	Cover Thread Carrier, for Styles 36200 PH, TH	1
-	36251 W	Cover Thread Carrier, for Styles 36200 PM, TM	1
28.	22565 A	Screw, for cover thread carrier	1

* When replacing the stationary knife clamp, order the clamp that has the same finish as the one being replaced.

#See page 39 for other presser foot shoes available.

PRESSER FOOT SHOE CHART

STANDARD FEET	PRESSER
1	36220
2	36220A
3	36220B
4	36220E
5	36220H
6	36220J
7	36220K
8	36220L
9	36220M
10	36220V

SELECTING PROPER PRESSER FOOT SHOES

THICKNESS OF SHOES

.014 THICK-----Used when sewing lightweight material, when light presser foot pressure is essential.

.020 THICK--- Used when sewing medium to heavyweight material, requiring more foot pressure.

WIDTH OF SHOES

NARROW SHOES--- Used for medium to heavier weight material

WIDE SHOES----- Used for light weight material

LENGTH OF SHOE TOE

SHORT TOE---Furnished as standard on presser foot , because it adapts easily to a variety of operations and material.

EXTENDED TOE-- Gives more feeding surface to the front of the presser foot , and may allow the operator to start the seam without raising the presser foot.

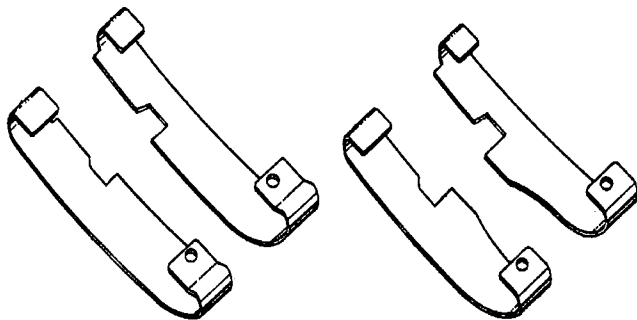

LONG SHOE

SHORT SHOE

PRESSER FOOT SHOE	RIGHT	LEFT	MATERIAL THICKNESS	
			.014	.020
36231AD		X		X
36232AD	X			X
36231AE		X		X
36232AE	X			X
36231AF		X		X
36232AF	X			X
36231AG		X		X
36232AG	X			X
36231AH		X		X
36232AH	X			X
36231AJ		X		X
36232AJ	X			X
36231AK		X		X
36232AK	X			X
36231AL		X		X
36232AL	X			X
36231AM		X		X
36232AM	X			X
36231AP		X		X
36232AP	X			X
36231AW		X	X	
36232AW	X		X	
36231AY		X	X	
36232AY	X		X	
36231AZ		X	X	
36232AZ	X		X	
36231BA		X	X	
36232BA	X		X	
36231BB		X	X	
36232BB	X		X	

PRESSER FOOT SHOE CHART

SHORT TOE	EXTENDED TOE	SHOE WIDTH	STANDARD ON PRESSER FOOT	CAN ALSO BE USED ON	FURNISHED ON MACH. STYLE	SAME AS
	X	3/8	NONE	1'2'3'6'7'8	NONE	
	X	11/32				
X		13/32 (9.5mm)		2'3'7'8	NONE	36231BB
X		3/8 (8.8mm)				36232BB
	X	13/32 (10.3mm)	NONE	1'2'3'6'7'8	NONE	
	X	3/8 (9.5mm)				
X		13/32 (10.3mm)	NONE	1'2'3'6'7'8	NONE	
X		3/8 (9.5mm)				
X		11/32 (8.7mm)	36220K	1'3'6'8		36231AY
X		11/32 (8.7mm)				36232AY
	X	11/32 (8.7mm)	NONE	1'2'3'6'7'8	36200AK,PA,PJ, 36200TA,TJ,TL	
	X	11/32 (8.7mm)				
	X	1/2 (12.7mm)	36220V	5'9	36200TL	36231AW
	X	9/32 (7.1mm)	36220E			36232AW
X		13/32 (9.5mm)		1'2'6'7'8		36231BA
X		3/8 (9.5mm)				36232BA
	X	1/2 (12.7mm)	36220H	4'9'10	36200PH,36200TH	
	X	5/16 (7.9mm)				
	X	1/2 (12.7mm)	36220M	4'5'10	36200PM,36200TM	
	X	9/32 (7.1mm)				
X	X	1/2 (12.7mm)	NONE	1'2'3'6'7'8	NONE	36231AK
X	X	9/32 (7.1mm)				36232AK
X		11/32 (8.7mm)	36220A,36220K, 36220L	1'2'3'6'7	36200AK,36200PA-TA 3620PJ,TJ	36231AH 36232AH
X		11/32 (8.7mm)				
	X	11/32 (8.7mm)	NONE	1'2'3'6'7'8	36200AK	36231AJ
	X	11/32 (8.7mm)			36200AK	36232AJ
X		13/32 (10.3mm)	36220B	1'2'6'7'8	36200PX,36200TX	36231AL 36232AL
X		3/8 (9.5mm)				
X		13/32 (10.3mm)	36220,36220J	2'3'7'8	NONE	36231AE 36232AE
X		3/8 (9.5mm)				

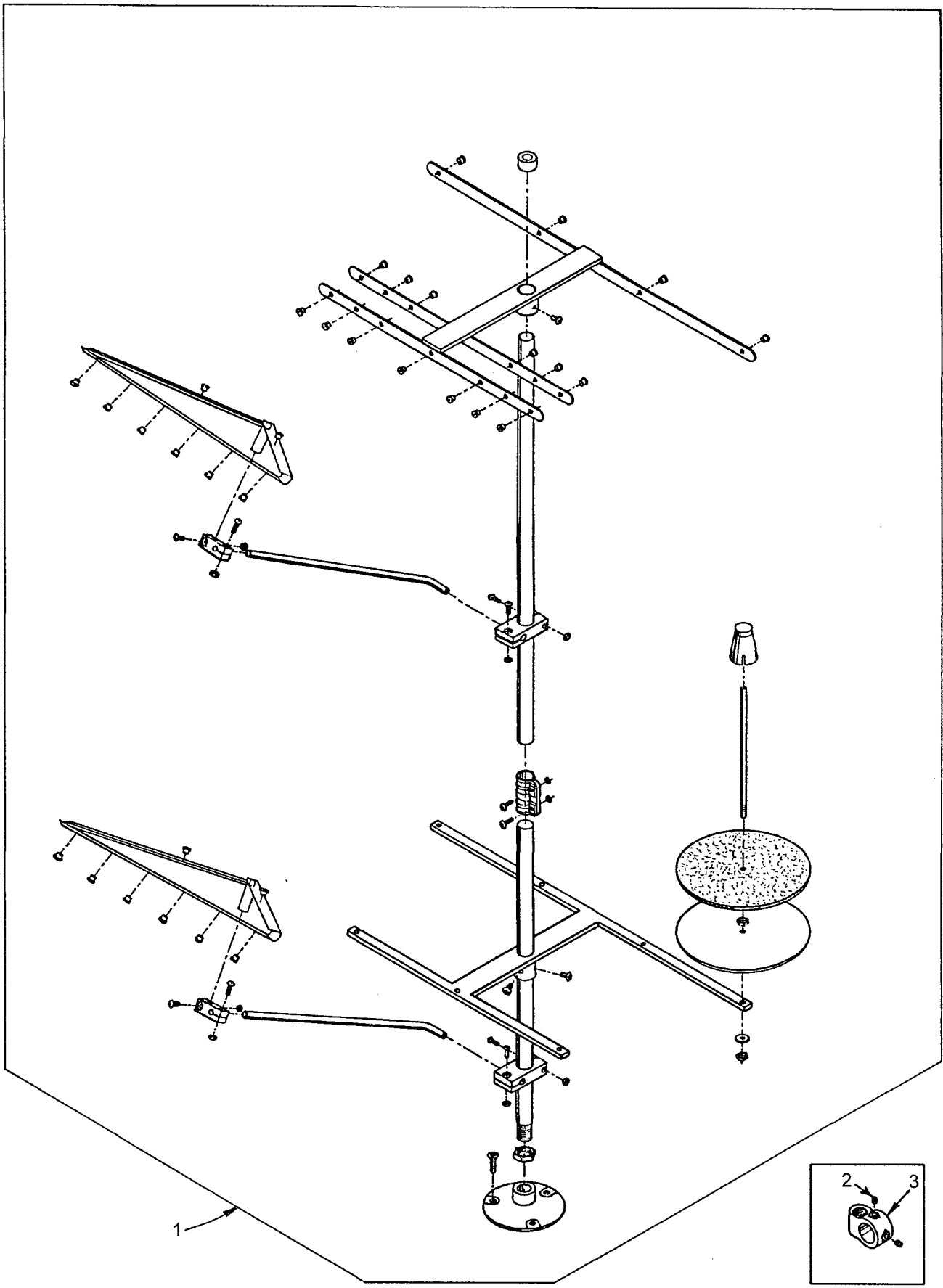

THREAD STAND

Ref. No.	Part No.	Description	Amt. Req.
1.	21101-S-7	Thread Stand, complete, for Styles 36200 AK, TA, TH, TJ, TM, TX	1
2.	21233 AJ	Bracket Connection, marked "AJ", for Style 36200 AK	1
-	21233 KS	Bracket Connection, marked "KS", for Styles 36200 PA, PH, PJ, PM, PX	1
3.	22651 CD-5	Screw, for bracket connection (21233AJ)	4
-	22651 CD-5	Screw, for bracket connection (21233KS)	2

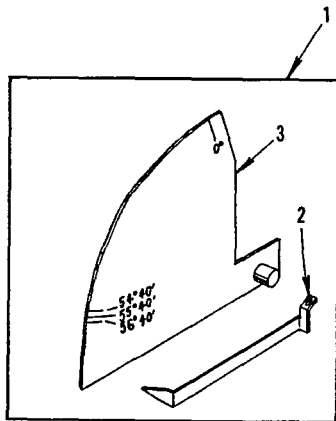
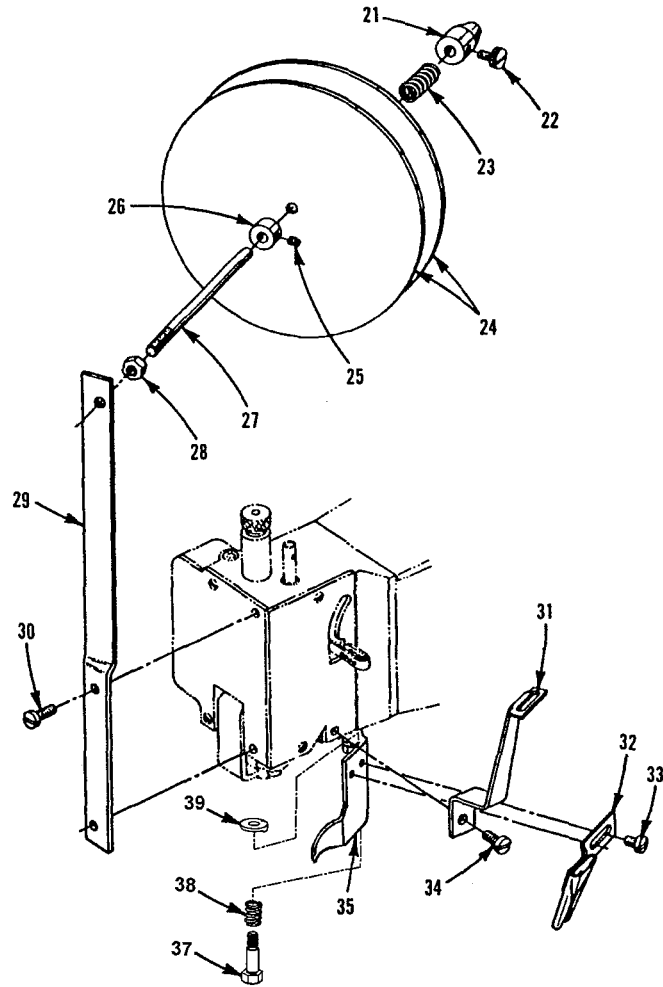
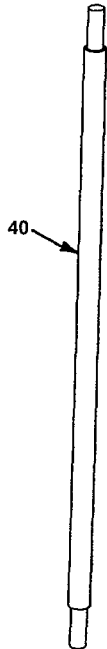
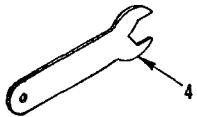
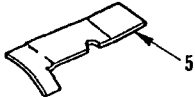
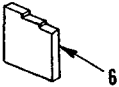
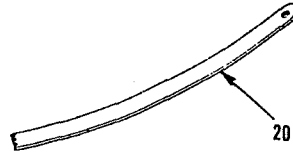
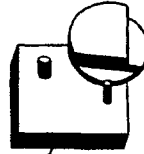
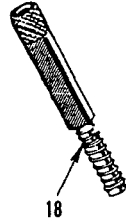
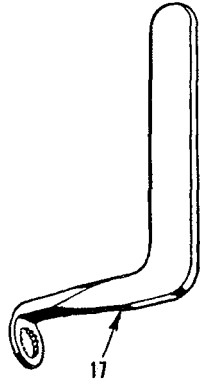
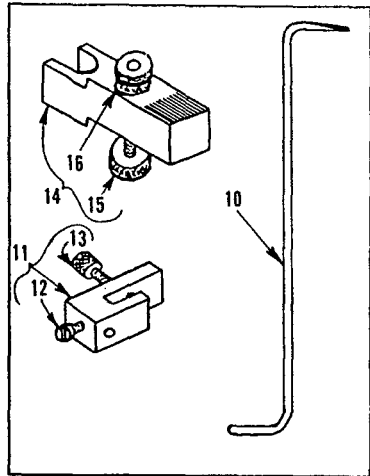

MISCELLANEOUS GAUGES & TAPE REEL PARTS

Ref. No.	Part No.	Description	Amt. Req.
1.	21227 CN	Looper Travel Gauge, complete	1
2.	21227 CM	Looper Travel Gauge Pointer	1
3.	21227 CS	Looper Travel Gauge Plate	1
4.	21388 AZ	Wrench, for driving link stud	1
5.	21227 CU	Looper Alignment Gauge	1
6.	21227 BU	Needle Height Gauge, for all Styles except 36200 PJ, PM, TJ, TM	1
-	21227 DS	Needle Height Gauge, for Styles 36200PJ, PM, TJ, TM	1
7.	21225 F-3/16	Looper Gauge	1
8.	21388 Y	Spanner Wrench	1
9.	21227 CG	Synchronizing Gauge, for looper and needle timing, complete	1
10.	21227 CK	Synchronizing Gauge Rod	1
11.	21227 CJ	Looper Clamp and Height Gauge	1
12.	22738	Screw	1
13.	22703 A	Screw	1
14.	21227 CH	Needle Setting Block	1
15.	14087	Thumbscrew	1
16.	1347 A	Nut	1
17.	TT85	Wrench, for 3/16" square nut on screw	1
18.	21227 BV	Looper Avoid Gauge	1
19.	21227 CV	Cover Thread Hook Gauge	1
*20.	23279 D	Folder Threader	1
*21.	753	Adjustable Axle Cone	1
*22.	188 D	Screw, for adjustable axle cone	1
*23.	51292 F-8	Spring, for tape holder disc	1
*24.	21178	Tape Holder Disc	2
*25.	88	Screw, for collar	1
*26.	161	Collar	1
*27.	21114 W	Tape Reel Axle	1
*28.	258 A	Nut, for tape reel axle	1
*29.	21171 Z	Tape Reel Frame	1
*30.	22729 A	Screw, for tape reel frame	2
*31.	21171 AA	Tape Guide	1
*32.	23401 P-7/16	Tape Folder	1
*33.	357	Screw, for tape folder	2
*34.	28	Screw, for tape guide	1
*35.	36279 E	Frame Chip Guard	1
36.	22777 B	Screw, for Frame Chip Guard, for Styles 36200PX, TX	1
37.	36279 B	Spring, for Frame Chip Guard, for Styles 36200PX, TX	1
38.	36279 A	Washer, for Frame Chip Guard, for Styles 36200PX, TX	1
39.	21227 AR	Torque Rod, for Needle Head	1

*Indicates tape holder parts for Styles 36200 PX, TX

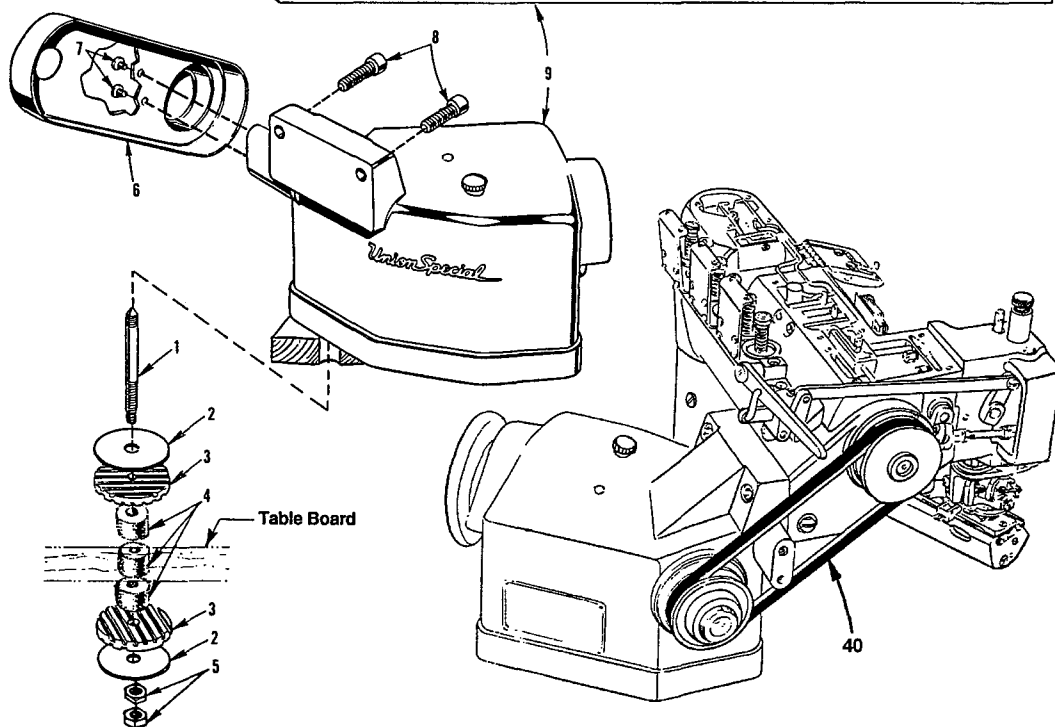
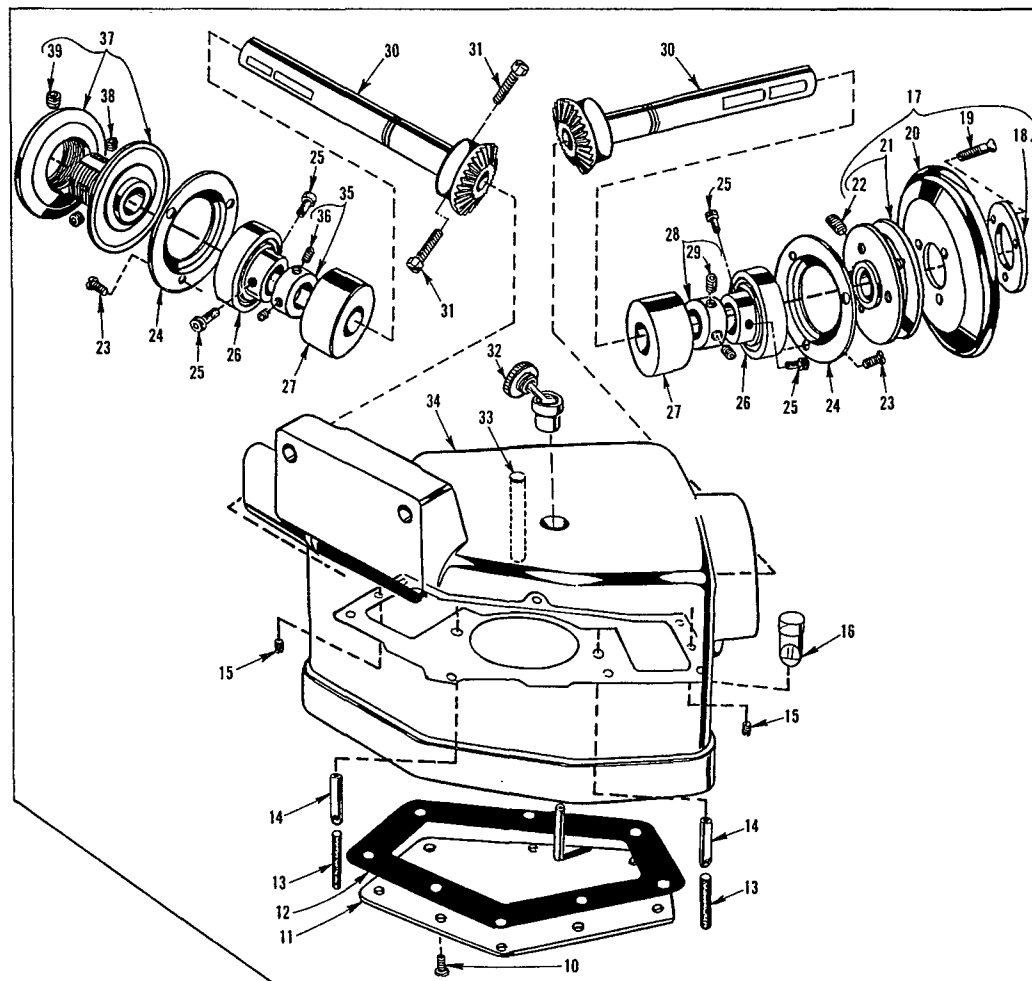

DRIVE UNIT, BELT GUARD & TABLE MOUNTING PARTS

Ref. No.	Part No.	Description	Amt. Req.
1.	35895 R	Mounting Stud	3
2.	21371 UE	Washer	6
3.	660-275	Neoprene Isolator	6
4.	660-161	Felt Isolator	9
5.	651 B-24	Nut	6
6.	36295 J	Belt Guard	1
7.	25 S	Screw, for belt guard	2
8.	22652 F-20	Screw	2
*9.	29480 CK	Auxiliary Support and Drive, complete	1
10.	22569 C	Screw, for bottom cover	8
11.	36295 Z	Bottom Cover	1
12.	36295 AA	Gasket	1
13.	666-128	Oil Wick	2
14.	36293 A	Oil Tube	2
15.	22571 A	Plug Screw	2
16.	51-120 BLK	Oil Gauge	1
17.	36295 H	Handwheel Assembly	1
18.	61321 L	Spacer Plate	1
19.	22574	Screw	3
20.	61321 J	Handwheel	1
21.	36295 F	Pulley	1
22.	22894 V	Screw	2
23.	22569 C	Screw	6
24.	36295 AC	Ball Bearing Cap	2
25.	36295 AE	Screw	4
26.	660-302	Ball Bearing	2
27.	36295 Y	Bushing	2
28.	21705	Collar	1
29.	22894 C	Screw	2
30.	36295 W	Gear Shaft	2
31.	22882 A	Screw	2
32.	666-96	Oil Filler Plug	1
33.	36295 AB	Gear Locating Pin	1
34.	36295 V	Machine Support	1
35.	21705	Collar	1
36.	22894 C	Screw	2
37.	36295 G	Variable Speed Pulley	1
38.	22878	Screw	2
39.	22650 AE-4	Socket Set Screw	1
*-	35829 AE	Auxiliary Support and Drive (not shown)	1
40.	21261M210	Belt	1

*These items available at extra send charge for Styles 36200 TA, TH, TJ, TM, TX.

NUMERICAL INDEX OF PARTS

<u>Part No.</u>	<u>Page No.</u>	<u>Part No.</u>	<u>Page No.</u>	<u>Part No.</u>	<u>Page No.</u>	<u>Part No.</u>	<u>Page No.</u>	<u>Part No.</u>	<u>Page No.</u>
109	17	22569 B	9	22849	29, 31	35847 X	15	36222 C	13
1096B	25, 27	22569 C	43	22878	43	35850 F	31	36223	13
12538	19	22569 D	11	22881 A	19	35851 L	27	36223 A	13
12865	27	22569G	25	22882 A	43	35851 M	23	36224 H	29
12934A	9, 25	22571 A	29, 43	22894 AM	13, 15	35851 N	23	36224 K	29
1347A	41	22571 B	13	22894 C	43	35859 D	19	36225	21
14087	41	22572 B	27	22894 E	15	35859 J	19	36226 A	21
150	33, 35	22574	43	22894 J	13, 19	35862 A	15	36226 B	21
15037 A	27	22578 H	21	22894 K	13	35866	23	36226 H	21
161	41	22580	13	22894 V	43	35866 A	11	36226 J	21
18	21, 23, 25, 27	22585	25	22894 W	13, 15	35866 B	11	36229 A-1	29
188 D	41	22585 A	13, 27	22894 W	21, 23	35876 U	29	36229 B	19
21101-S-7	39	22585 C	17, 19	22894 W	31	35880 M	19	36230 C	33, 35
21114 W	41	22585 C	29	22894 X	25	35883 AL	11	36230 D	33, 35
21171 AA	41	22587 B	15	23279 D	41	35883 G	31	36230 G	33
21171 Z	41	22587 E	13, 21	23401 P-7/16	41	35884 M	29	36230 J	33
21178	41	22587 E	23	23420 DB	29	35884 R	31	36230 P	33, 35
21225 F-3/16	41	22587 H	21	23423 X	29	35887 AE	9	36230 R	35
21227 AR	41	22596	29, 31	23424 Z	29	35887 AF	11	36230 S	35
21227 BU	41	22596 B	15	25 S	43	35887 AG	9	36230 U	33
21227 BV	41	22650 AE-4	43	255	17	35887 M	9	36230 V	35
21227 CG	41	22651 CD-5	39	258	23	35887 R	9	36231 AH	33
21227 CH	41	22652 A-6	27	258 A	17, 27	35887 X	9	36231 AL	33
21227 CJ	41	22652 F-20	43	258 A	41	35887 Z	11	36231 AM	35
21227 CK	41	22653 B-8	19	269	21, 23	35888 N	9	36231 AP	35
21227 CM	41	22653 E-24	29	269	25, 27	35888 T	9	36232 AH	33
21227 CN	41	22703 A	41	28	19, 41	35889 H	9	36232 AL	33
21227 CS	41	22711	9	28 A	19	35890 E	11	36232 AM	35
21227 CU	41	22716 A	29, 35	28 C	11	35890 P	9	36232 AP	35
21227 CV	41	22729 A	41	29101 J	13, 23	35893 G	9	36234 C	21
21227 DS	41	22729 C	21, 23	29103 T	13, 21	35893 H	9	36234 E	21
21233 AJ	39	22729 C	25, 27	29105 BH	11	35894 J	13	36234 F	21
21233 KS	39	22729 M	25	29472 AC	13	35894 L	13	36234 G	21
21261M210	43	22731	33, 35	29472 Y	13	35895 R	43	36234 M	21
21371 UE	43	22733 B	11	29472XC	9	35895 X	13	36236	23
21388 AZ	41	22733 G	23	29478 CS	21	35895 Y	13, 15	36236 A	23
21388 Y	41	22738	41	29478 CT	23	35897 BU	13	36236 B	23
21705	43	22738 B	29	29478 CU	27	35897 BV	13	36236 C	23
21756 G	13	22738 C	19	29478 CZ	31	35897 BW	13	36236 E	21
22 KH	9, 29	22738 G	33, 35	29478 FF	23	35897 BY	15	36236 F	21
22504 C	23	22738 H	19	29480 CK	43	35897 CK	19	36236 G	21
22513	19	22738 P	33, 35	318	19	36 G	25	36236 H	21, 23
22516 A	9	22747	21, 27	33174 B	21	36203	29	36236 J	23
22517	17	22759 A	9	357	41	36204	9	36236 K	23
22519	17	22766	15, 31	35751 G	27	36204 A	9	36237	23
22519 F	13	22767 A	25	35760 D	11	36205 A	21	36237 A	23
22524	19	22768 B	11	35761 D	11	36205 B	21	36237 E	31
22528	21	22777 B	19, 41	35763 F	15	36205 H	21	36237 H	31
22539 AA	9	22784 F	17	35763 G	15	36205 J	21	36237 J	31
22539 AL	31	22791 D	11	35766 B	23	36208 A	27	36237 K	31
22539 M	9	22791 E	31	35767	19	36210	27	36237 L	31
22539 T	11	22795 B	27	35781 D	11	36218	19	36238	31
22560 A	19, 31	22797	15	35792	17	36218 J	19	36238 F	31
22562 A	15	22798	29	35792 T	17	36220 A	33	36240	29
22562 A	17, 29	22799 B	11	35815 C	15	36220 B	33	36240 J	29
22562 A	33, 35	22799 N	25	35817 E	19	36220 H	35	36244	21
22564	15	22801	13, 29	35829 AE	43	36220 K	33	36244 A	21
22564 B	9, 11	22829	11	35836 C	23	36220 L	33	36245 B	27
22564 D	27	22839	9	35842 J	23	36220 M	35	36248	27
22565 A	13, 33	22839 D	17	35846	23	36221 D	15	36249	27
22565 A	35	22845 M	21	35846 B	23	36222 A	15	36249 A	31

NUMERICAL INDEX OF PARTS

<u>Part No.</u>	<u>Page No.</u>	<u>Part No.</u>	<u>Page No.</u>	<u>Part No.</u>	<u>Page No.</u>	<u>Part No.</u>	<u>Page No.</u>
36249 B27	36279 A41	36295 W43	660-27543
3625033, 35	36279 B41	36295 Y43	660-30243
36250 B33, 35	36279 C33, 35	36295 Z43	660-9359
36250 G33, 35	36279 D33, 35	36296 A29	661-15031
36250 J33	36279 E41	36296 B29	664 F-1619
36250 J35	36279 H33	36297 J13	666-12843
36251 B25	36279 L19	36297 M13	666-33813
36251 C25	36279 M19	36298 F17	666-34129
36251 D19	36279 N19	36298 G17	666-9643
36251 E33, 35	36280 A17	39145 A27	667 D-1629
36251 F33, 35	36280 C17	39592 AK17	73 A9, 11, 29
36251 FA33, 35	36280 D17	39593 C9	73 C9
36251 G33, 35	36280 J19	41071 G9, 13	75341
36251 H33	36280 N17	41255 B21, 27	7715, 23, 27
36251 J33, 35	36280 S17	4324623	8372 A19
36251 K29, 33	36280 T17	476125, 27	8617
36251 K35	36280 U17	51-120 BLK43	87 A31
36251 L33, 35	36280 V17	51054 A15	87 U21
36251 M15	36280 W17	51254 K15	8827, 41
36251 N15	3628231	5125919	909, 13
36251 P25	36283 B29	51292 F-217	939
36251 V25	36283 C29	51292 F-417	93 A9
36251 W33, 35	36283 E29	51292 F-517	9417, 33, 35
36253 A27	36283 F29	51292 F-841	97 A25, 27
36253 B27	36283 G29	5233627	98 A29
36253 G27	36283 H29	52841 H25	999-19631
362569	36283 J29	52848 B25	B35305550009
36256 A9	36283 K31	52848 C25	C36224 A29
36256 B31	3628429	52958 C9	C36224 J29
3626011	36284 C31	52958 F9	C50092 S17
3626125	36284 E29	53129, 31	CL219, 11
36261 A13	36284 F31	53636 C27	J87 J31
3626315	3628631	53831	LA5289
36264 B19	36286 B31	56354 D15	SS7110510SP11
36264 D15	3628919	56390 E9	TT8541
36264 E19	36289 A19	56392 F17	WO319
36264 F19	36289 B19	60078 Z31		
36270 B25	36289 H19	60427		
3627111	36289 J19	6042 A9, 19		
36271 A11	36290 A11	6042 A23		
36271 E11	36290 B11	605 A25		
36271 G11	36290 D9	61321 J43		
36271 H11	36292 K17	61321 L43		
36273 A25	36292 M17	62238 A21, 23		
36273 C25	36292 N17	62271 B11		
36273 D25	36292 P17	63251 H35		
36273 F25	36293 A43	651 B-2443		
36273 G25	36293 B9	660-111531		
36273 J25	36293 E9	660-111731		
36273 K25	36293 G31	660-16143		
36273 M25	36294 B19	660-20215, 25		
36273 N25	36294 C19	660-20611		
3627819	36295 AA43	660-20713, 23		
36278 A19	36295 AB43	660-2129		
36278 C27	36295 AC43	660-21527		
36278 F19	36295 AE43	660-219 D25		
36278 H19, 25	36295 F43	660-219 P13		
36278 J25	36295 G43	660-22021, 31		
36278 K19	36295 H43	660-22127		
36278 L19	36295 J43	660-254 C17		
36278 M19	36295 V43	660-26119		

Union Special Corporation
Corporate Office
One Union Special Plaza
Huntley, IL 60142
Phone: 847•669•5101
Fax: 847•669•4454

Union Special GmbH
European Distribution Center
Raiffeisenstrasse 3
D-71696 Möglingen, Germany
Tel: 49•07141•247•0
Fax: 49•07141•247•100

JUKI CORPORATION
INTERNATIONAL SALES DIVISION
8-2-1, KOKURYO - CHO,
CHOFU-SHI, TOKYO 182, JAPAN
PHONE: 03(3430)4001-5
FAX: 03(3430)4909 . 4914 . 4984



JUKI
Union Special